



Multilift RESIDENTIAL

VERTICAL PLATFORM LIFT

PLANNING GUIDE

Applicable Codes:

ASME A17.1

ASME A18.1

Part No. 000736
08-m01-2019

Purpose of this guide

This guide assists architects, contractors, and lift professionals to incorporate the Multilift Vertical Platform Lift into a residential or public building design. The design and manufacture of the Multilift Vertical Platform Lift meets the requirements of the following codes and standards:

- ASME A18.1-2003 Section 5 (Private)
- ASME A18.1-2005 Section 5 (Private)
- ASME A18.1-2008 Section 5 (Private)
- ASME A18.1-2011 Section 5 (Private)
- ASME A18.1-2014 Section 5 (Private)
- ASME A18.1-2017 Section 5 (Private)
- ASME A17.1-1996 Section 21 (Private)

We recommend that you contact your local authority having jurisdiction to ensure that you adhere to all local rules and regulations pertaining to vertical platform lifts.

IMPORTANT NOTICE

This Planning Guide provides nominal dimensions and specifications useful for the initial planning of a vertical platform lift project. Dimensions and specifications are subject to change without notice due to continually evolving code and product applications.

Before beginning actual construction, please consult Savaria or the authorized Savaria dealer in your area to ensure you receive your site-specific installation drawings with the dimensions and specifications for your project.

Visit our website (www.savaria.com) for the most recent Multilift drawings and dimensions.

How to use this guide

- 1 Determine your client's intended use of the lift.
- 2 Determine the local code requirements.
- 3 Determine the site installation parameters.
- 4 Determine the cab type and hoistway size requirements.
- 5 Plan for electrical requirements.

History

December 10, 2010 - Initial release of new format

January 21, 2011 - Added Mobile Multilift drawing on pg. 24

February 24, 2011 - Added information for automatic access ramp to "Features" in Specifications table on pg. 6

June 1, 2011 - Updated all drawings to reflect current design

October 18, 2012 - Added enclosure drawings - pg. 22 to 26; Added 3-gate drawing - pg 27

October 25, 2012 - Added enclosure to cab types in specifications table on pg. 6; Revised list of drawings (removed 42" width) - pg. 13; Revised enclosure drawings (removed 42" width) - pg. 22 to 26

April 25, 2013 - Correct power supply amperage from 20A to 15A in specifications table on pg. 6

July 8, 2013 - Added Noise Level to specifications table on pg. 6

December 5, 2013 - Added 42x48, 42x54 and 42x60 cab sizes to specifications table on pg. 6; added 42x48, 42x54 and 42x60 cab sizes to list of drawings on page 12 and a NOTE that the 42" wide cab sizes are not self-supporting and need wall mounting; added new drawings on pages 14, 16, 18, 20, 22, 24, 26 and 28

December 17, 2013 - Added "must be a dedicated electrical line" to power supply specification in table on pg. 6

March 13, 2014 - Revised "Features" in Specifications table on pg. 6

November 5, 2014 - Revised Applicable Codes on pg. 3

December 11, 2014 - Changed title to reflect RESIDENTIAL and revised codes on page 3

January 20, 2015 - Added 2014 code in section above

September 24, 2015 - Added Daily Cycle to specifications table on page 6

March 7, 2016 - Removed copyright from cover page; Savaria Corporation back to Savaria Concord Lifts, Inc.

March 28, 2016 - Revised Power supply spec in table on page 6

February 16, 2017 - Revised temperature spec in specs table on page 6

February 26, 2018 - Removed pages 41 to 43

September 27, 2018 - Added ASME 18.1-2017 to code list above

January 8, 2019 - Added spec for distance between 2 landings on page 6

Description

The Multilift Vertical Platform Lift is designed to provide easy access from one landing to another. The versatile design of this lift can be adapted to most architectural requirements and its rugged construction allows for outdoor or indoor use. It is an ideal deck lift for home use and is also approved for certain commercial accessibility projects as well. The Multilift, with its ACME screw drive system, provides safe and reliable operation.

Lift components

The Multilift consists of a tower and a platform as shown in Figure 1.

Figure 1: Typical lift, outdoor, unenclosed, no platform gate

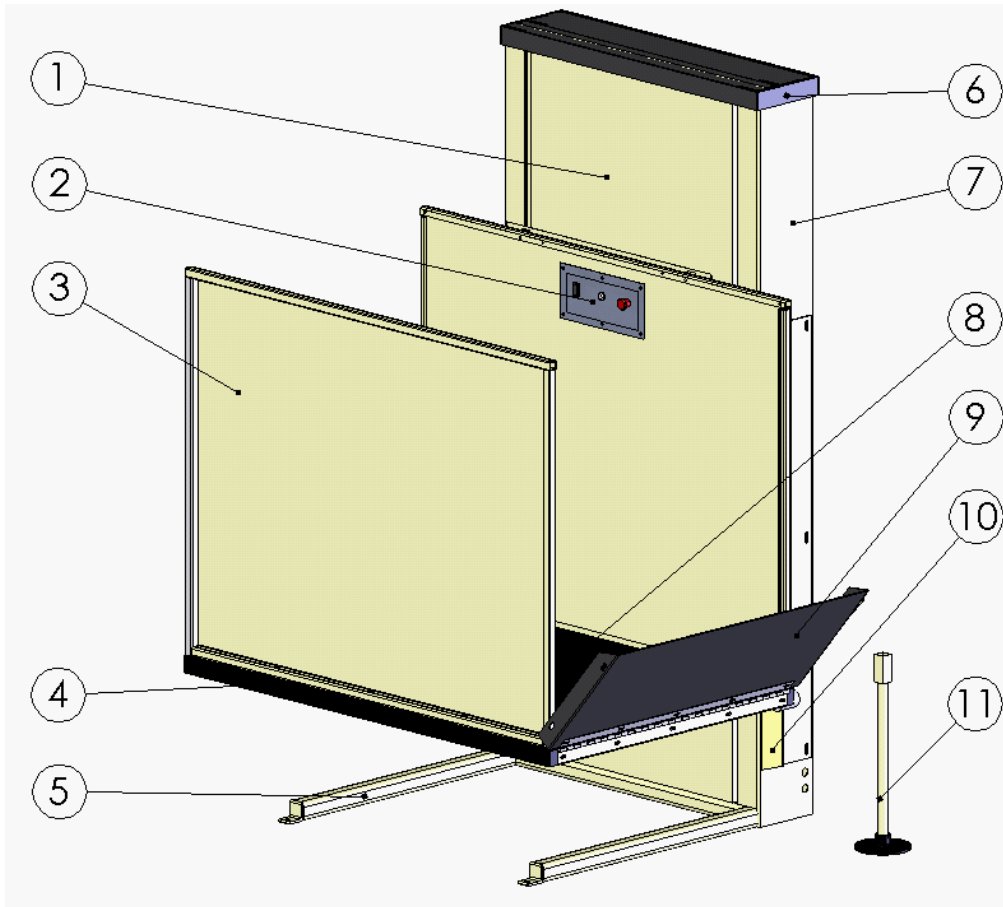

Number	Description	Number	Description
1	Front tower panel	7	Tower
2	Car operating panel (C.O.P.)	8	Non-skid platform
3	Side guard panel	9	Automatic access ramp
4	Safety underpan sensors	10	Access ramp channel
5	Self support base	11	Manual lowering device
6	Tower cover	-	-

Drive tower components

The Multilift drive tower components are shown in Figure 2.

Figure 2: Drive tower

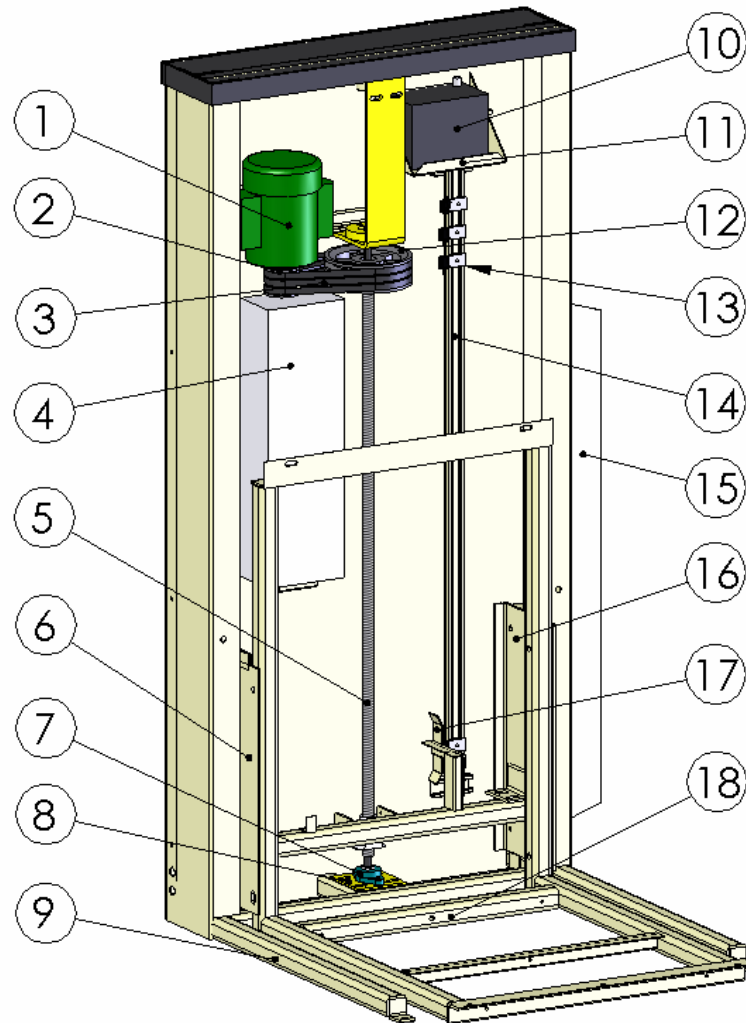

Number	Description	Number	Description
1	Motor	10	Battery (optional)
2	Main pulley	11	Battery tray
3	V strap	12	Pulley
4	Controller box	13	Limit switches (may vary)
5	Acme screw	14	Unistrut
6	Left roller guide	15	Access ramp channel
7	Lower bearing	16	Right roller guide
8	Lower bearing plate	17	Cam assembly
9	Self support base	18	Carriage assembly

Specifications

Multilift specifications

Applications	Residential (indoor/outdoor); commercial (U.S.A.)
Load capacity	750 lb (340 kg)
Maximum travel distance	48" (1219 mm); optionally 72" (1829 mm)
Levels serviced	2
Distance between 2 landings	8" (203 mm) minimum
Travel speed	8 ft/min (0.04 m/s)
Temperature	-20 °F to +122 °F (-29 °C to +50 °C)
Noise level (for typical installation)	65.9 dBA (up direction); 65.0 dBA (down direction) Measured at a height of 1m, distance of 1m, in front of the motor with all panels on
Daily cycle	Normal: 10; Heavy: 25; Excessive: 40 Maximum starts in 1 hour on standard installation: 10 NOTE: Please consult your Sales Representative if there a chance you may exceed these amounts.
Cab types/sizes	Type 2 (enclosed and unenclosed hoistway): <ul style="list-style-type: none"> • 34" x 48" (863 mm x 1219 mm) • 34" x 54" (863 mm x 1371 mm) • 34" x 60" (863 mm x 1524 mm) Type 3/4: (enclosed and unenclosed hoistway): <ul style="list-style-type: none"> • 35" x 47" (889 mm x 1194 mm) • 35" x 53" (889 mm x 1346 mm) • 35" x 59" (889 mm x 1499 mm) Type 2 with platform gate (unenclosed hoistway): <ul style="list-style-type: none"> • 36" x 48" (914 mm x 1219 mm) • 36" x 54" (914 mm x 1371 mm) • 36" x 60" (914 mm x 1524 mm) Type 3/4 with platform gate (unenclosed hoistway): <ul style="list-style-type: none"> • 36" x 47" (914 mm x 1194 mm) • 36" x 53" (914 mm x 1346 mm) • 36" x 59" (914 mm x 1499 mm) All enclosure -Type 2, Type 3, Type 3 with 45" opening, Type 4, Type 4 with 45" opening <ul style="list-style-type: none"> • 36" x 48" (914 mm x 1219 mm) • 36" x 54" (914 mm x 1371 mm) • 36" x 60" (914 mm x 1524 mm) Type 2, 3, or 4 (with/without platform gate and with enclosure) <ul style="list-style-type: none"> • 42" x 48" (1067 mm x 1219 mm) • 42" x 54" (1067 mm x 1371 mm) • 42" x 60" (1067 mm x 1524 mm) NOTE that the 42" wide cab units are not self-supporting and need wall mounting.
Side guard panels	42 1/8" (1070 mm) side guard panels on platform
Cab access	Front/rear access - standard (platform Type 2) 90 degree access - optional (platform Type 3 and 4)
Power supply	120 VAC, 20 A, 60 Hz, single phase (must be a dedicated electrical line)
Drive system	Acme screw and back-up nut 1 hp (0.75 Kw) motor, 110 VAC Optional 1 hp, 24-volt battery model available
Control system	Electronic-free relay logic controller
Finish	Beige electrostatic powder coat paint on all steel surfaces and vacuum-formed plastics
Features	Call/send stations at landings Continuous-pressure type buttons Operating control buttons on platform Emergency manual lowering/raising device Low-voltage controls Underpan sensors Non-skid platform surface Automatic access ramp (16"); field reversible to suit installation needs Emergency stop button

Site construction details

The self-supporting base must be able to support at least 3000 lb (13.3 kN) per Figure 3 and must be anchored to a concrete slab (or floor) per Figure 4. Make sure the slab (floor) surface is level.

Figure 3: Floor loading diagram

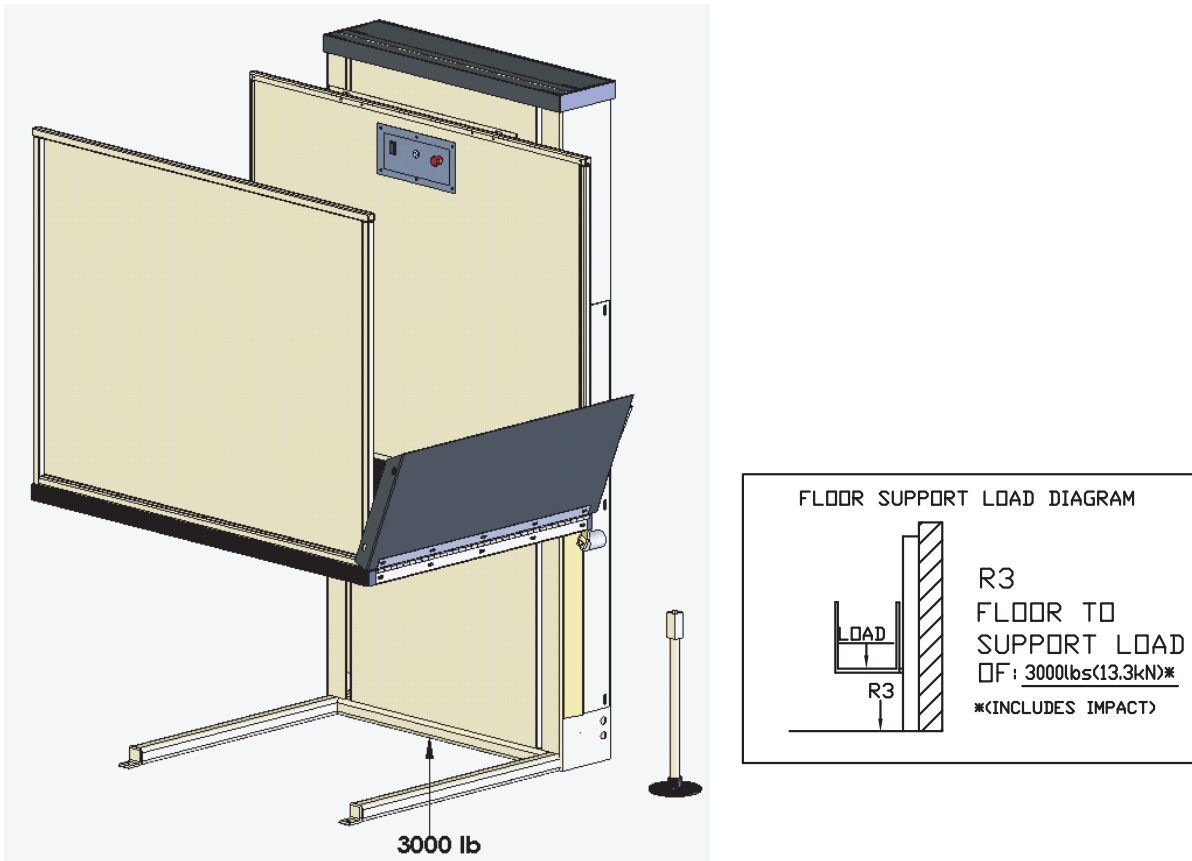

Figure 4: Anchor points

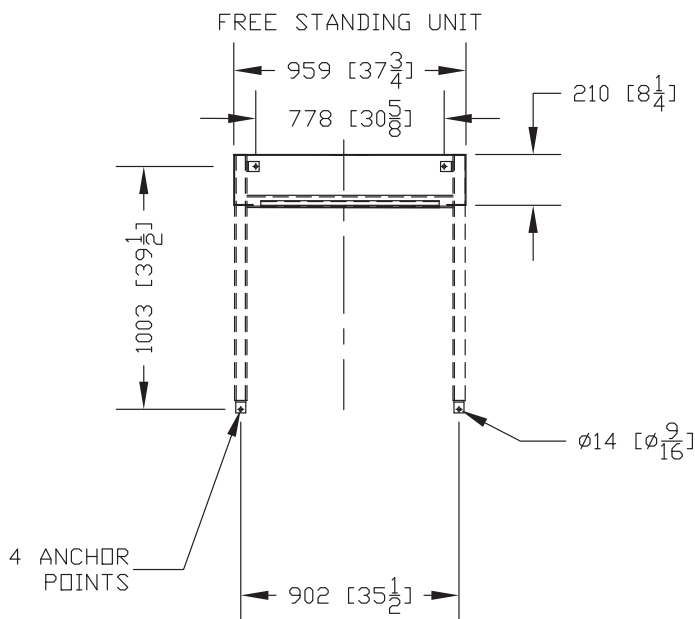
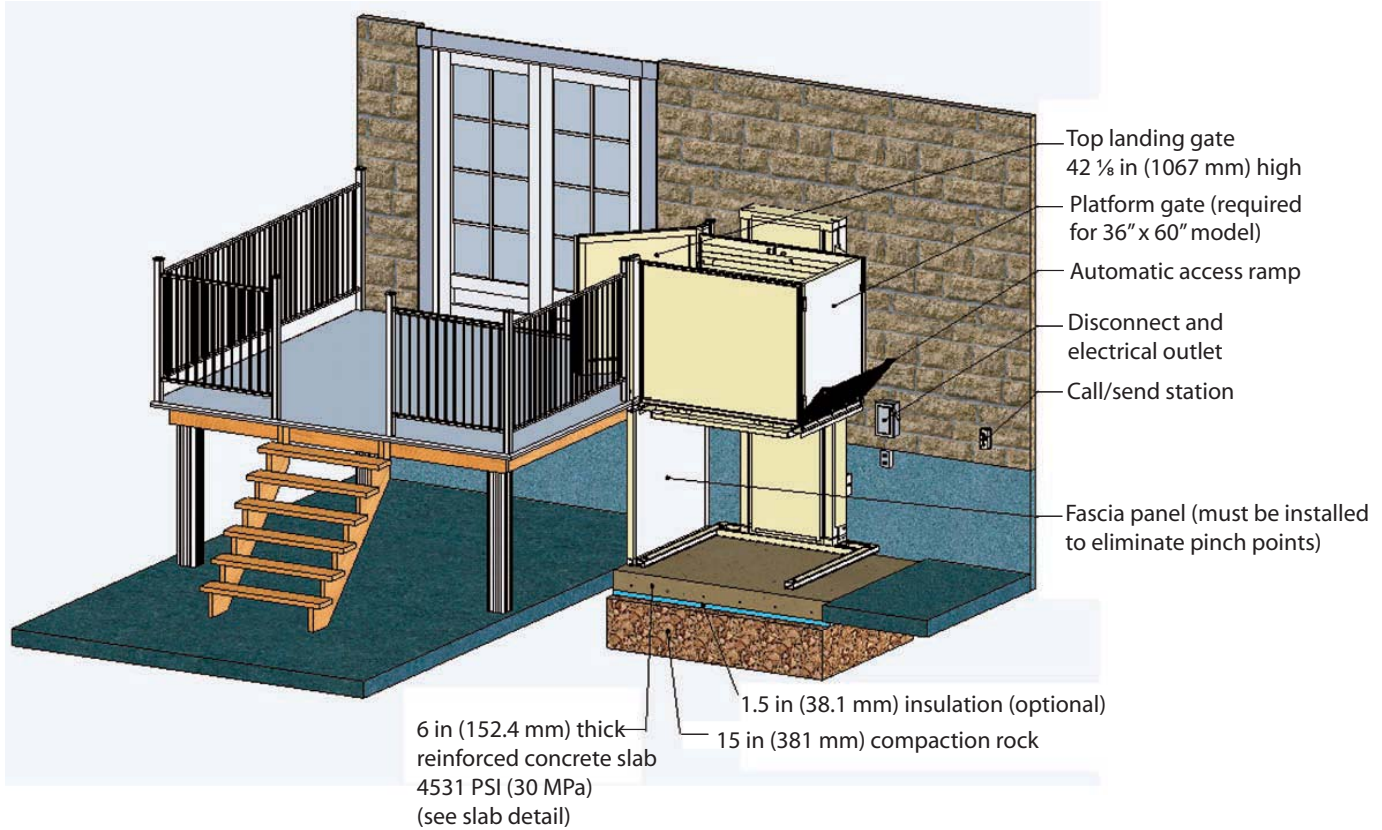

Figure 5 illustrates the site construction details for a typical outdoor application.

Figure 5: Sample unenclosed outdoor application



Outdoor applications need a strong and stable surface that will not move throughout the years. For this reason, it is essential, when the temperature can get below the freezing point, to insert an insulate sheet between the concrete slab and the compaction rock. Figure 6 illustrates the concrete slab detail for a typical outdoor application.

Figure 6: Concrete slab detail

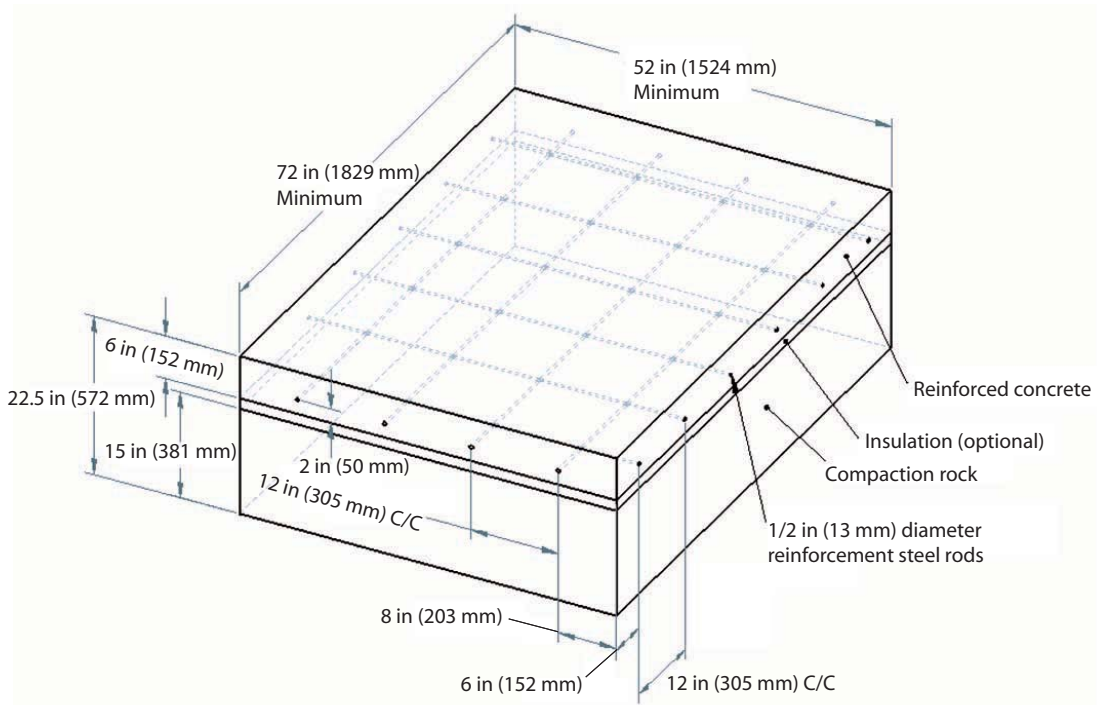

Landing gate/door details

Landing gate/door details are specific to each job site. Be sure to refer to your site-specific installation drawings.

There are two options that can be used when preparing for installation of the gate (or door with sill angle). Figure 7 illustrates the two options for a gate. Refer to the Installation Guide for details on installing the landing gate or door.

- Option 1 – Notch out the landing so that the gate angle bracket (or door sill angle) is flush with the vertical landing surface.
- Option 2 – Install a 1/4" fascia panel to fill in the gap in the vertical landing surface from underneath the gate angle bracket (or door sill angle) down to the floor/ground. If your site has a hoistway or pit, be sure to add 1/4" to those dimensions to account for the 1/4" fascia panel.

Figure 7: Options used when installing a gate

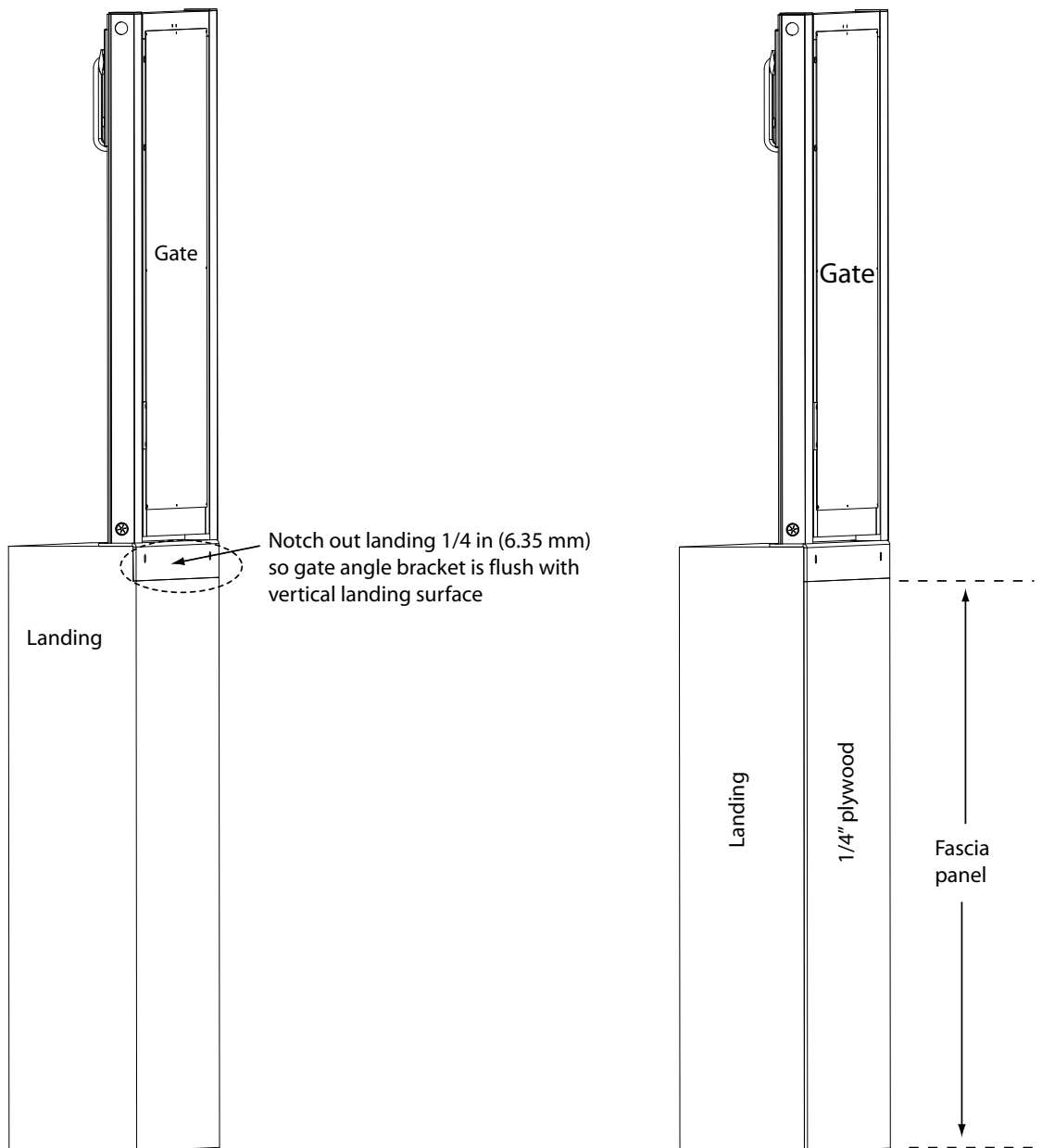

Notch out landing to install gate

Install fascia panel for gate

Commercial requirements

Following are the requirements for commercial applications.

ASME A17.1: An enclosure or hoistway is required (see Figure 8 below).

Figure 8: Hoistway requirements

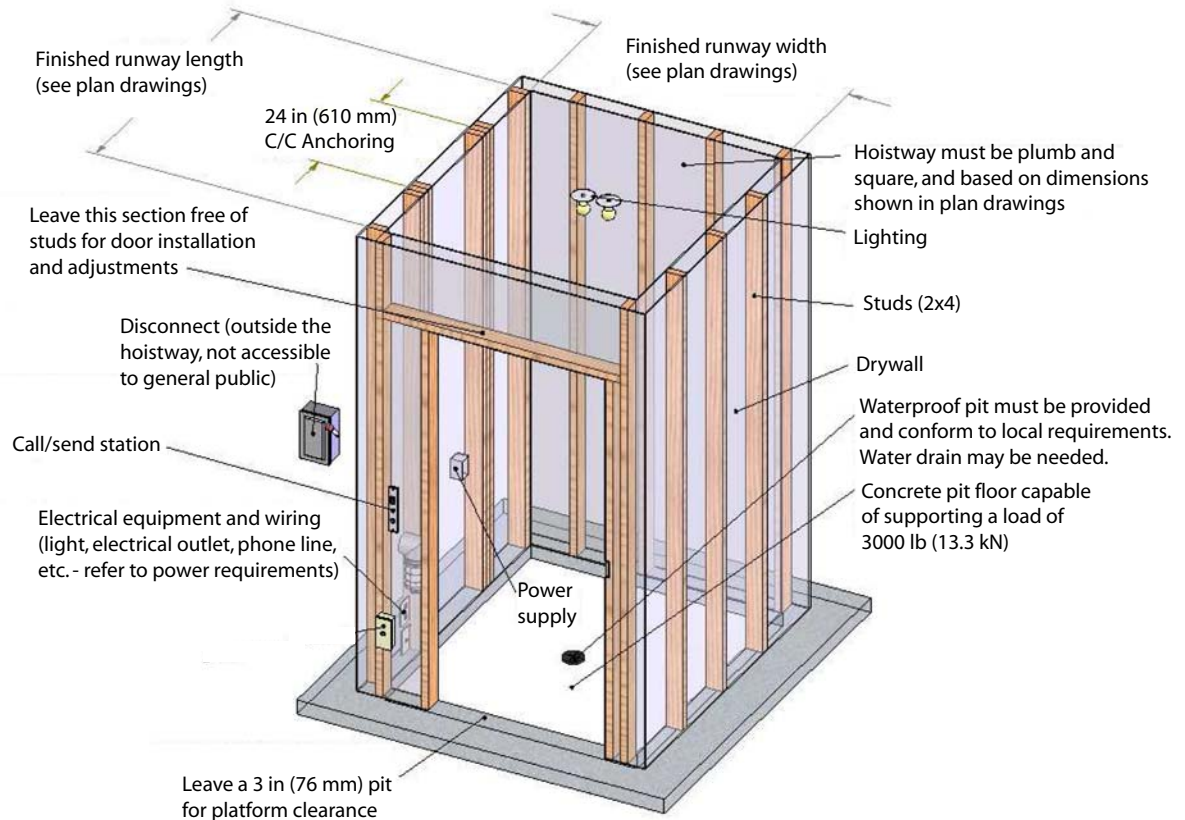

ASME A17.1/A18.1: The items listed below are required.

- Grab bar (hand rail)
- Emergency light on platform
- Controller redundancy
- Emergency stop/alarm
- Platform gate or hoistway
- Top landing gate
- Disconnect (provided by others)
- Door locks

CSA: The Multilift is not approved for commercial use in Canada.

Cab types

Type 2 cab (standard)

For type 2 cabs, entry and exit are available from both ends of the platform.

Figure 9: Type 2

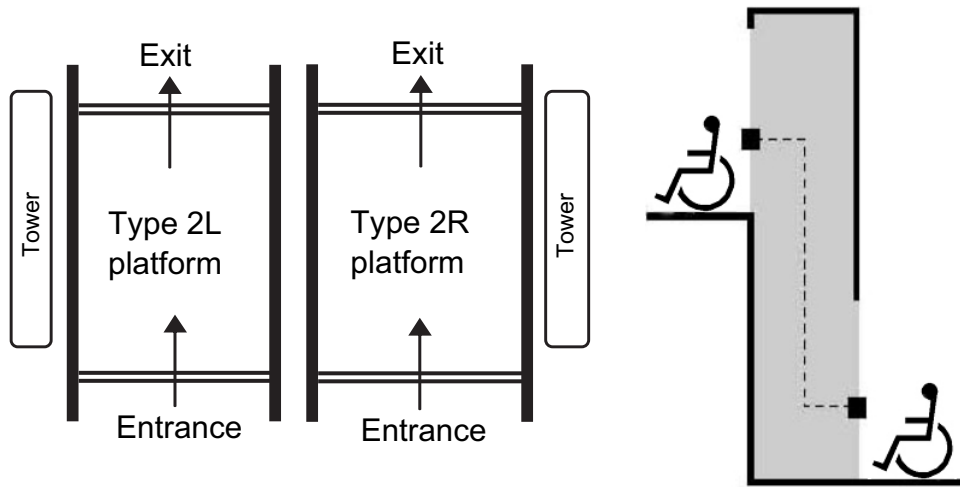

Type 3 and 4 cab (optional)

For type 3 and 4 cabs, entry and exit are available from one end and one side of the platform.

Figure 10: Type 3 and 4

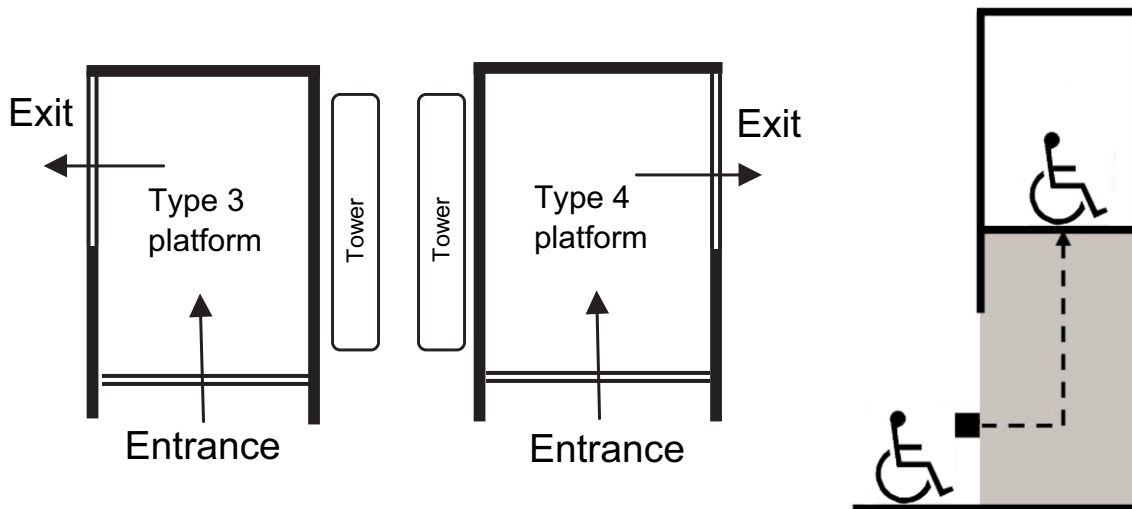

Drawings

The next several pages provide various Multilift drawings. Always refer to your installation drawings for details specific to your site.

- Elevation and plan view drawings (for the different cab types and sizes)
 - Type 2, enclosed hoistway, 34" x 48", 34" x 54", 34" x 60"
 - Type 3, enclosed hoistway, 35" x 47", 35" x 53", 35" x 59"
 - Type 4, enclosed hoistway, 35" x 47", 35" x 53", 35" x 59"
 - Type 2, unenclosed hoistway, 34" x 48", 34" x 54", 34" x 60"
 - Type 3, unenclosed hoistway, 35" x 47", 35" x 53", 35" x 59"
 - Type 4, unenclosed hoistway, 35" x 47", 35" x 53", 35" x 59"
 - Type 2 with platform gate, unenclosed hoistway, 36" x 48", 36" x 54", 36" x 60"
 - Type 3 with platform gate, unenclosed hoistway, 36" x 47", 36" x 53", 36" x 59"
 - Type 4 with platform gate, unenclosed hoistway, 36" x 47", 36" x 53", 36" x 59"
 - Type 2 without platform gate – 42" x 48", 42" x 54", 42" x 60"
 - Type 3 without platform gate – 42" x 48", 42" x 54", 42" x 60"
 - Type 4 without platform gate – 42" x 48", 42" x 54", 42" x 60"
 - Type 2 with platform gate – 42" x 54", 42" x 60"
 - Type 3 (42" B side opening) with platform gate – 42" x 60"
 - Type 4 with platform gate – 42" x 54", 42" x 60"
 - Type 2, enclosure, 36" x 48", 36" x 54", 36" x 60"
 - Type 3, enclosure, 36" x 48", 36" x 54", 36" x 60"
 - Type 3 (45" opening), enclosure, 36" x 48", 36" x 54", 36" x 60"
 - Type 4, enclosure, 36" x 48", 36" x 54", 36" x 60"
 - Type 4 (45" opening), enclosure, 36" x 48", 36" x 54", 36" x 60"
 - Type 2, enclosure, 42" x 48", 42" x 54", 42" x 60"
 - Type 3, enclosure, 42" x 48", 42" x 54", 42" x 60"
 - Type 4, enclosure, 42" x 48", 42" x 54", 42" x 60"
 - Type 2, three gates, 36" x 48", 36" x 54", 36" x 60"
- Two sample landing gate layout drawings are provided
 - 42" x 36" auto left-hand gate
 - 42" x 36" manual left-hand gate
- Mobile Multilift drawing

Note: For specifications on other landing gates and doors, go to our website www.savaria.com, select the "architects and builders" tab at the top of the page and then select "Doors and Gates" from the menu on the left-hand side of the page.

The link is as follows: <http://www.savaria.com/architects/drawings/doors-gates/index.php>.

Figure 11: Elevation and plan view - type 2, enclosed hoistway, 34" cab

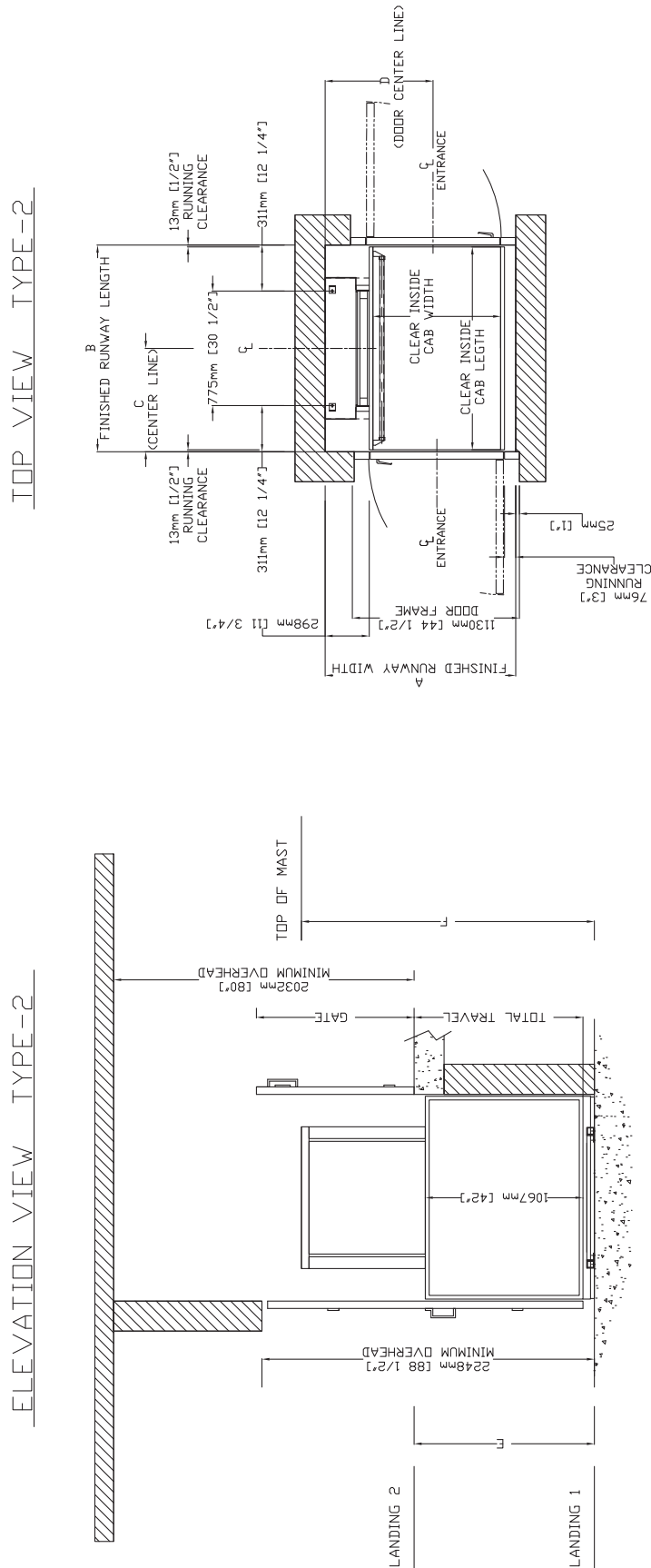

TABLE 1 - MAST HEIGHT

E	F
Max. Travel	Mast Height with 2" CAP
mm (Inches)	mm (Inches)
1219 (48")	2032 80
1829 (72")	2642 104

TABLE 2 - HOISTWAY DIMENSION

CLEAR INSIDE CAB WIDTH	CLEAR INSIDE CAB LENGTH		A		B		C		D	
	mm	Inches	mm	Inches	mm	Inches	mm	Inches	mm	Inches
864	34	1219	1289	50 3/4	1245	49	622	24 1/2	730	28 3/4
864	34	1372	1289	50 3/4	1397	55	699	27 1/2	730	28 3/4
864	34	1524	1289	50 3/4	1549	61	775	30 1/2	730	28 3/4

Figure 12: Elevation and plan view - type 3, enclosed hoistway, 35" cab

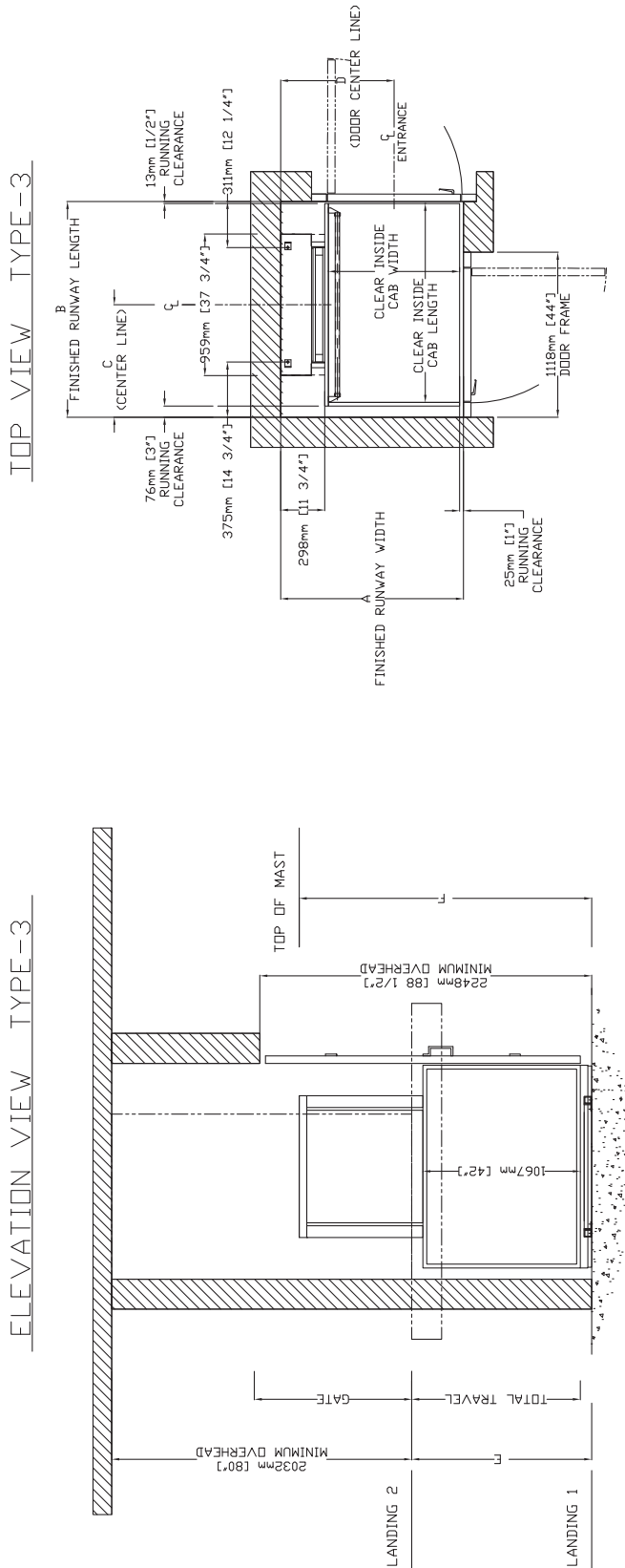

TABLE 2 - HOISTWAY DIMENSION

CLEAR INSIDE CAB WIDTH	CLEAR INSIDE CAB LENGTH		A		B		C		D	
	mm	Inches	FINISHED RUNWAY WIDTH	FINISHED RUNWAY LENGTH	FINISHED RUNWAY LENGTH	TOWER CENTER LINE	DOOR CENTER LINE (IN CASE OF 36" DOOR)			
889	35	1194	47	1306	51 1/2	762	30	768	30 1/4	
889	35	1346	53	1461	57 1/2	762	30	768	30 1/4	
888	35	1489	59	1613	63 1/2	762	30	768	30 1/4	

TABLE 1 - MAST HEIGHT

E	F	
	Max. Travel (Inches)	Mast Height with 2" CAP
1219 (48")	mm	Inches
1829 (72")	2032	80
	2642	104

Figure 13: Elevation and plan view - type 4, enclosed hoistway, 35" cab

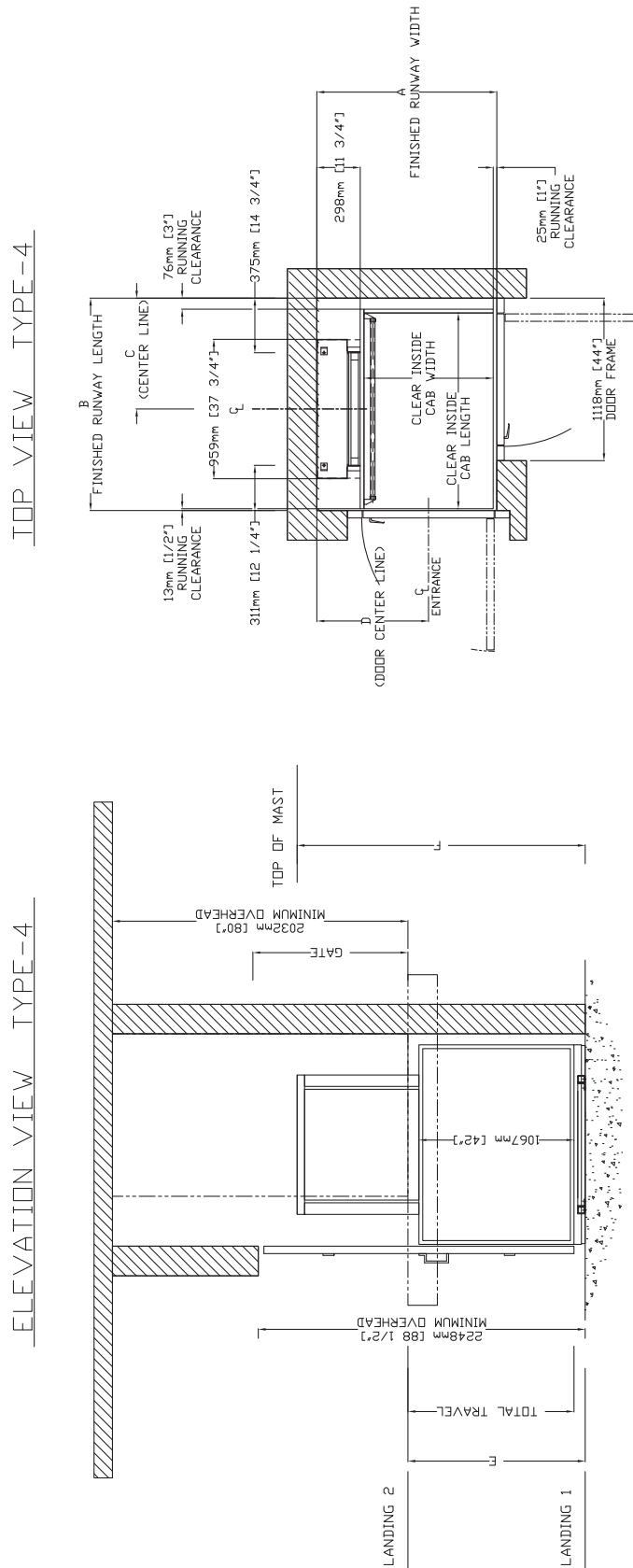

TABLE 1 - MAST HEIGHT

E	F
Max. Travel	Mast Height with 2" CAP
mm (inches)	mm (inches)
1219 (48")	2032 80
1829 (72")	2642 104

TABLE 2 - HOISTWAY DIMENSION

CLEAR INSIDE CAB		A		B		C		D	
WIDTH	CLEAR INSIDE CAB LENGTH	FINISHED RUNWAY WIDTH	FINISHED RUNWAY LENGTH	TOWER CENTER LINE	DOOR CENTER LINE (IN CASE OF 36" DOOR)				
mm	mm	Inches	mm	mm	Inches				
889	1194	48 3/4	1308	762	30				
889	1346	48 3/4	1461	762	30 1/4				
889	1499	48 3/4	1613	762	30				

Figure 14: Elevation and plan view - type 2, unenclosed hoistway, 34" cab

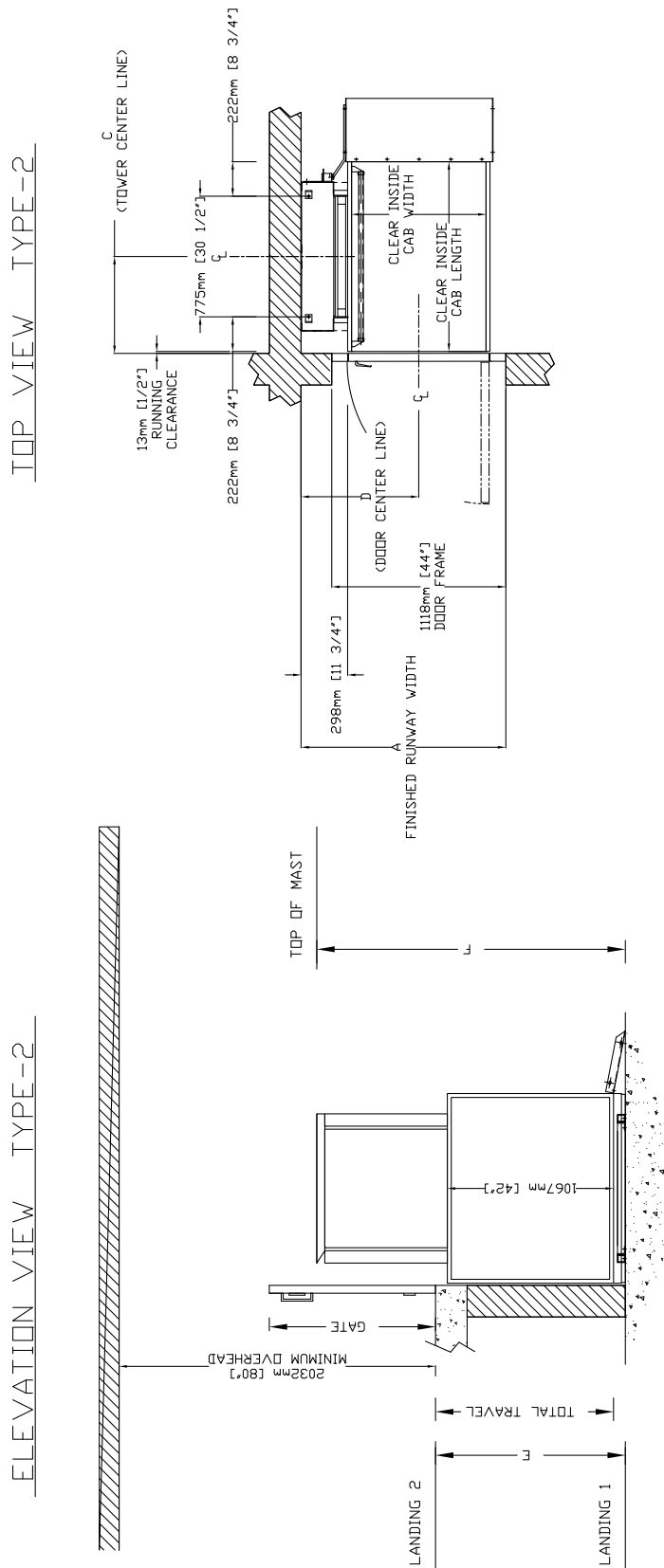

TABLE 1 - MAST HEIGHT

E		F	
Max. Travel	Mast Height with 2" CAP	mm	Inches
1219 (48")	2032	80	80
1829 (72")	2642	104	104

TABLE 2 - HOISTWAY DIMENSION

CLEAR INSIDE CAB WIDTH	A		B		C		D	
	FINISHED RUNWAY WIDTH	FINISHED RUNWAY LENGTH	FINISHED RUNWAY WIDTH	FINISHED RUNWAY LENGTH	TOWER CENTER LINE	TOWER CENTER LINE	DOOR CENTER LINE	DOOR CENTER LINE
mm	mm	mm	mm	mm	mm	mm	mm	mm
864	1314	1314	51 3/4	51 3/4	622	24 1/2	756	29 3/4
864	1372	1372	54	51 3/4	699	27 1/2	756	29 3/4
864	1524	1524	60	51 3/4	775	30 1/2	756	29 3/4

Figure 15: Elevation and plan view - type 3, unenclosed hoistway, 35" cab

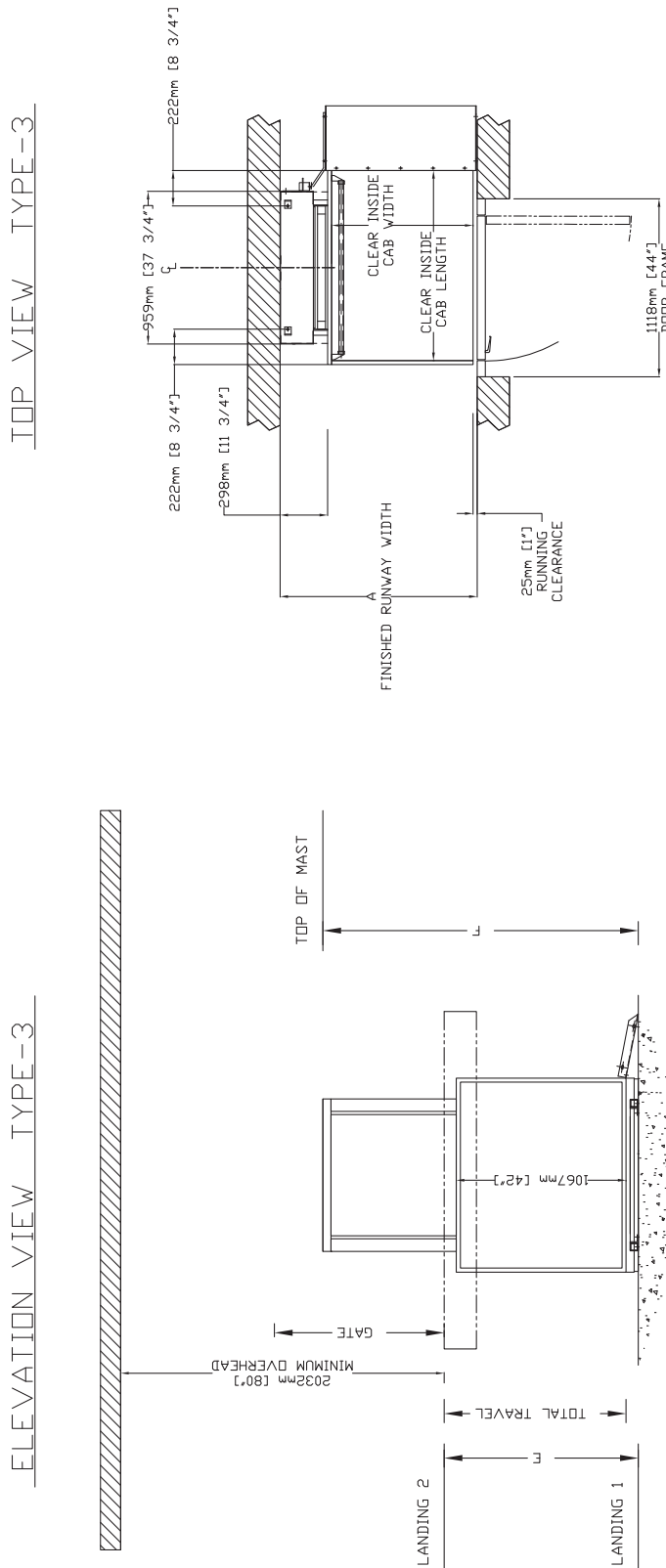

TABLE 2 - HOISTWAY DIMENSION

CLEAR INSIDE CAB WIDTH	CLEAR INSIDE CAB LENGTH		FINISHED RUNWAY WIDTH		FINISHED RUNWAY LENGTH		TOWER CENTER LINE		DOOR CENTER LINE (IN CASE OF 36" DOOR)	
	mm	Inches	mm	Inches	mm	Inches	mm	Inches	mm	Inches
889	35	1194	47	1238	48	3/4	N/A	N/A	N/A	N/A
889	35	1346	53	1238	48	3/4	N/A	N/A	N/A	N/A
889	35	1499	59	1238	48	3/4	N/A	N/A	N/A	N/A

TABLE 1 - MAST HEIGHT

E Max.Travel	F Mast Height with 2" CAP	
	mm	Inches
1219 (48")	2032	80
1829 (72")	2642	104

Figure 16: Elevation and plan view - type 4, unenclosed hoistway, 35" cab

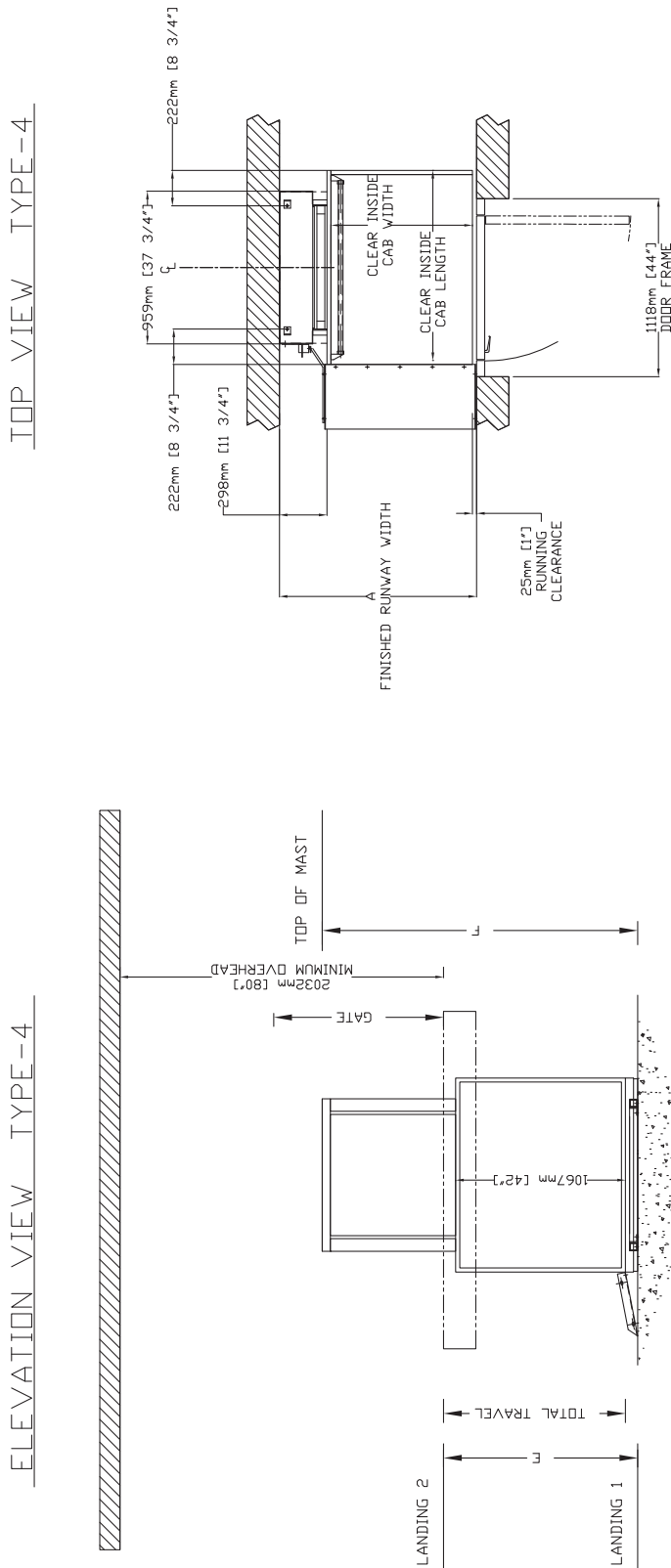

TABLE 1 - MAST HEIGHT

E	F
Max.Travel	Mast Height with 2" CAP
mm (Inches)	mm (Inches)
1219 (48")	2032 80
1829 (72")	2642 104

TABLE 2 - HOISTWAY DIMENSION

CLEAR INSIDE CAB WIDTH	CLEAR INSIDE CAB LENGTH		A		B		C		D	
	mm	Inches	mm	Inches	mm	Inches	mm	Inches	mm	Inches
889	1194	47	1238	48 3/4						
889	1346	53	1238	48 3/4	N/A					
889	1499	59	1238	48 3/4						N/A

Figure 17: Elevation and plan view - type 2 with platform gate, unenclosed hoistway, 36" cab

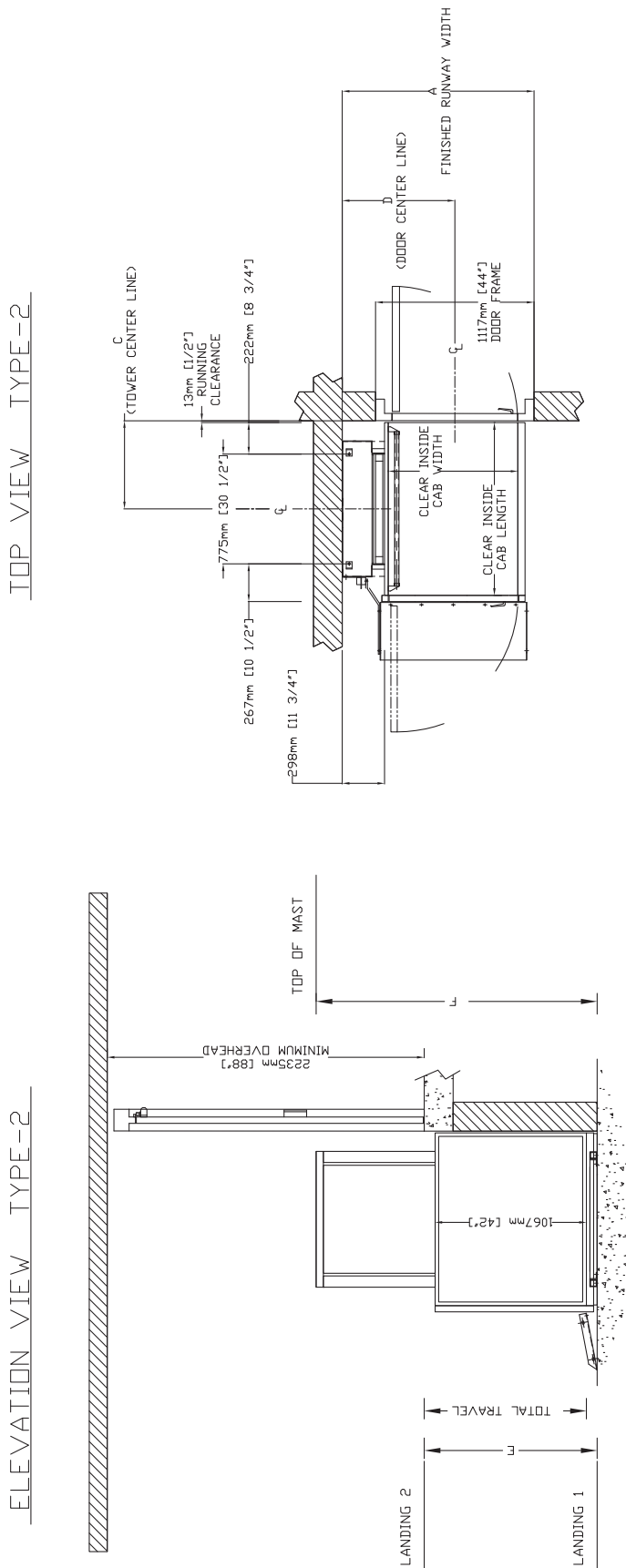

TABLE 2 - HOISTWAY DIMENSION

CLEAR INSIDE CAB WIDTH	CLEAR INSIDE CAB LENGTH		FINISHED RUNWAY WIDTH		FINISHED RUNWAY LENGTH		TOWER CENTER LINE		DOOR CENTER LINE (IN CASE OF 36" DOOR)		
	mm	Inches	mm	Inches	mm	Inches	mm	Inches	mm	Inches	
914	36	1219	48	1353	53 1/4	622	24 1/2	794	31 1/4	794	31 1/4
914	36	1372	54	1353	53 1/4	689	27 1/2	794	31 1/4	794	31 1/4
914	36	1524	60	1353	53 1/4	775	30 1/2	794	31 1/4	794	31 1/4

TABLE 1 - MAST HEIGHT

E Max.Travel	F Mast Height with 2" CAP	
	mm	Inches
1219 (48")	2032	80
1829 (72")	2642	104

Figure 18: Elevation and plan view - type 3 with platform gate, unenclosed hoistway, 36" cab

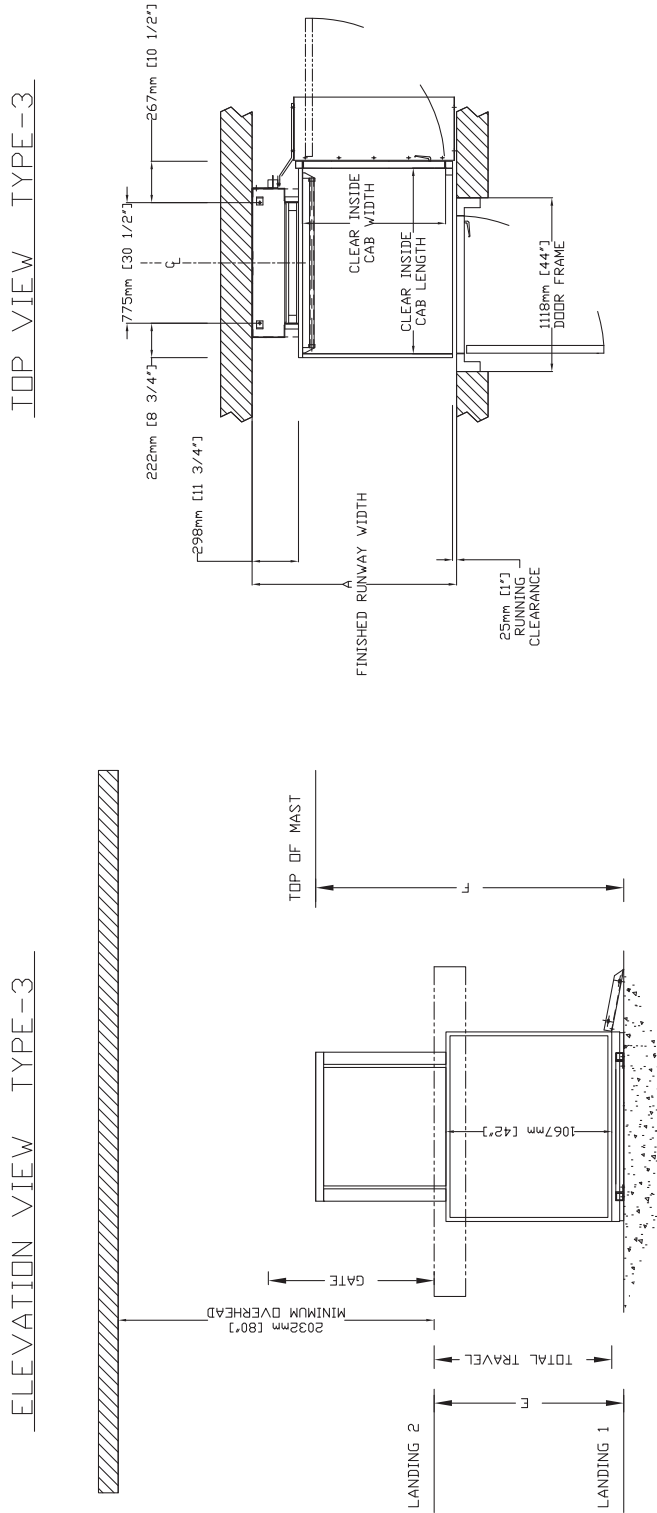

TABLE 2 - HOISTWAY DIMENSION

CLEAR INSIDE CAB WIDTH	CLEAR INSIDE CAB LENGTH		FINISHED RUNWAY WIDTH		FINISHED RUNWAY LENGTH		TOWER CENTER LINE		DOOR CENTER LINE (IN CASE OF 36" DOOR)	
	mm	Inches	mm	Inches	mm	Inches	mm	Inches	mm	Inches
914	36	1194	1314	51 3/4	N/A	N/A	N/A	N/A	N/A	N/A
914	36	1346	1314	51 3/4	N/A	N/A	N/A	N/A	N/A	N/A
914	36	1499	1314	51 3/4	N/A	N/A	N/A	N/A	N/A	N/A

TABLE 1 - MAST HEIGHT

E	F
Max. Travel	Mast Height with 2" CAP
mm (Inches)	mm (Inches)
1219 (48")	2032
1829 (72")	2642
	104

Figure 19: Elevation and plan view - type 4 with platform gate, unenclosed hoistway, 36" cab

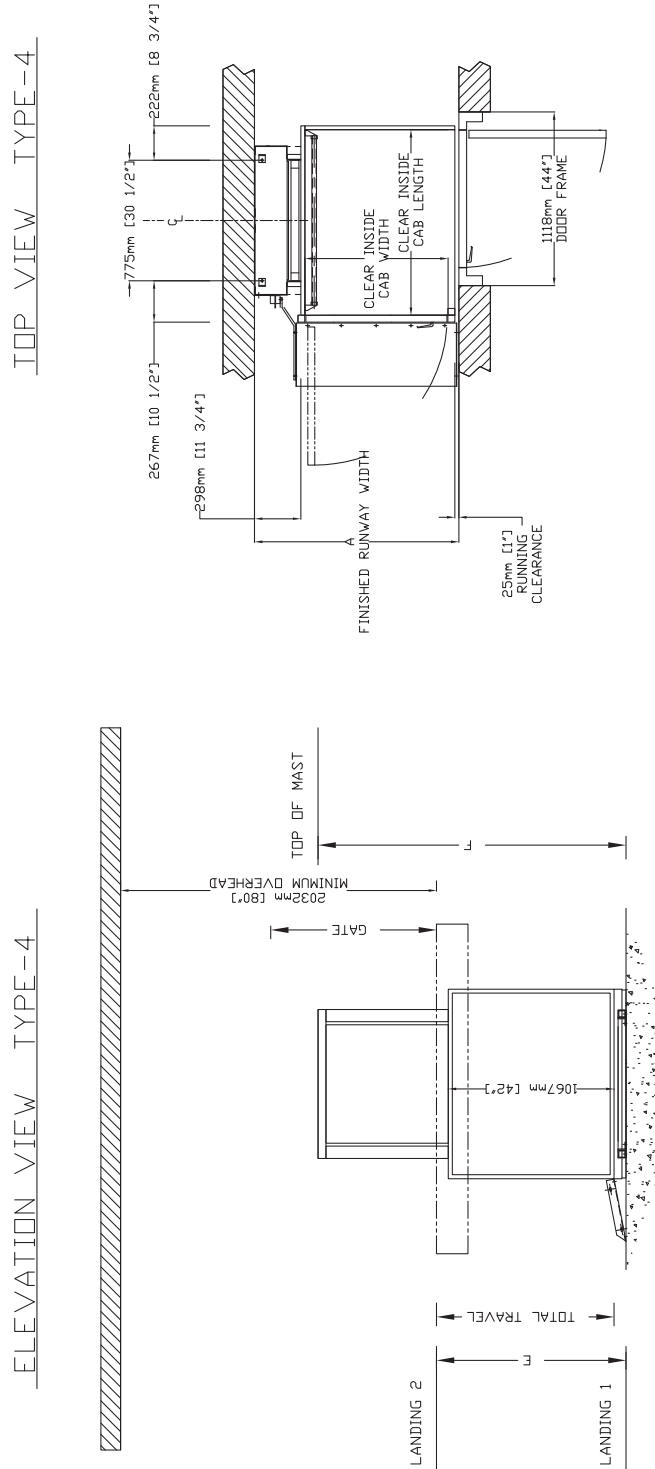

TABLE 2 - HOISTWAY DIMENSION

CLEAR INSIDE CAB WIDTH	CLEAR INSIDE CAB LENGTH		A FINISHED RUNWAY WIDTH		B FINISHED RUNWAY LENGTH		C TOWER CENTER LINE		D DOOR CENTER LINE (IN CASE OF 36" DOOR)	
	mm	Inches	mm	Inches	mm	Inches	mm	Inches	mm	Inches
914	36	1194	47	1314	51	3/4	N/A	N/A	N/A	N/A
914	36	1346	53	1314	51	3/4	N/A	N/A	N/A	N/A
914	36	1469	59	1314	51	3/4	N/A	N/A	N/A	N/A

TABLE 1 - MAST HEIGHT

E Max. Travel	F Mast Height with 2" CAP	
	mm	Inches
1219 (48")	2032	80
1829 (72")	2642	104

Figure 20: Elevation and plan view – type 2 without platform gate, 42” cab

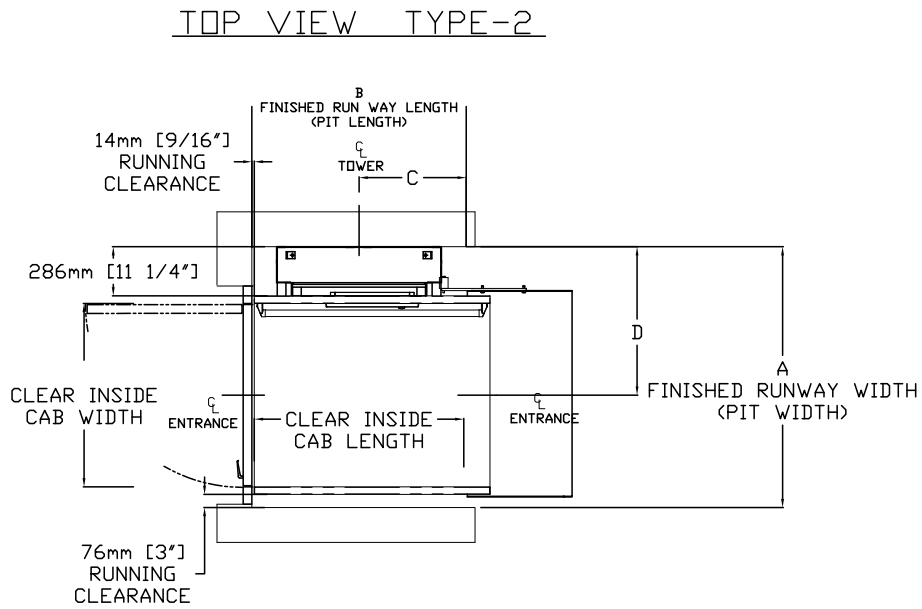
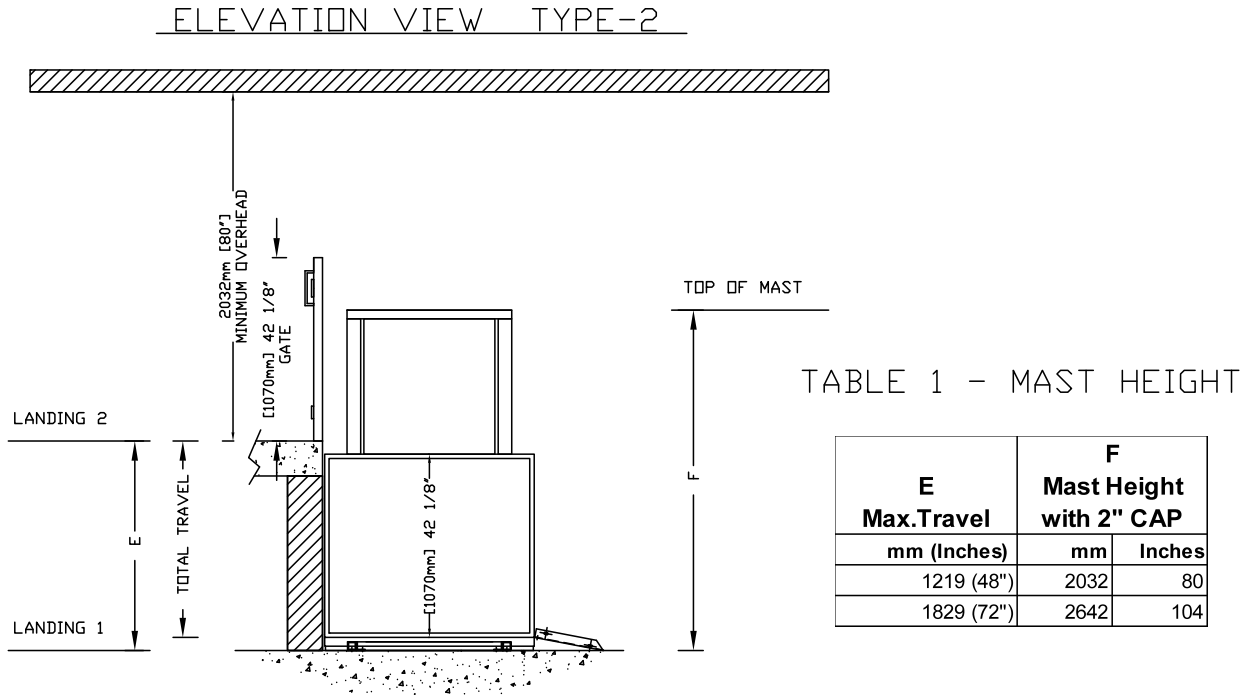

TABLE 2- HOISTWAY DIMENSION

CLEAR INSIDE CAB WIDTH		CLEAR INSIDE CAB LENGTH		A FINISHED RUNWAY WIDTH		B FINISHED RUNWAY LENGTH		C TOWER CENTER LINE		D DOOR CENTER LINE (IN CASE OF 42" DOOR)	
mm	Inches	mm	Inches	mm	Inches	mm	Inches	mm	Inches	mm	Inches
1067	42	1219	48	1511	59 1/2	1248	49 1/8	624	24 9/16	864	34
1067	42	1372	54	1511	59 1/2	1400	55 1/8	700	27 9/16	864	34
1067	42	1524	60	1511	59 1/2	1553	61 1/8	776	30 9/16	864	34

Figure 21: Elevation and plan view – type 3 without platform gate, 42" cab

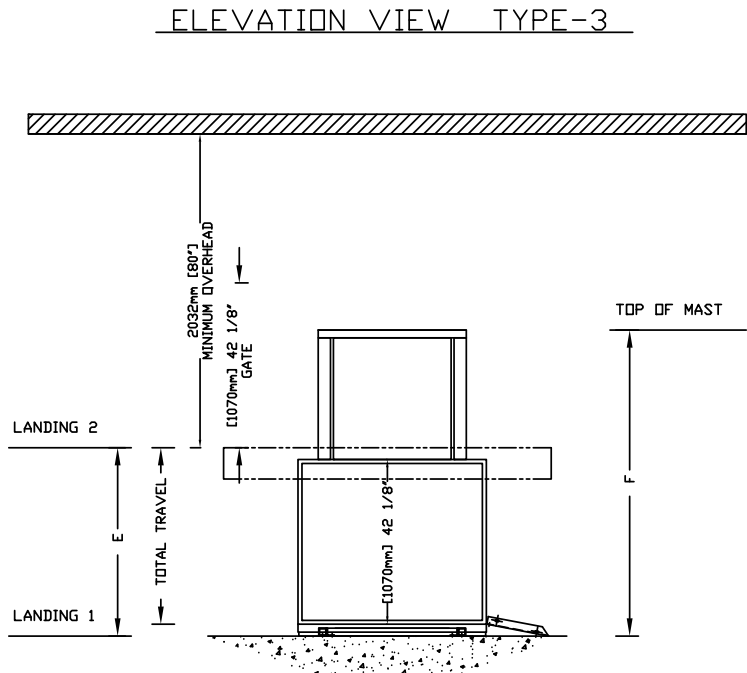

TABLE 1 - MAST HEIGHT

E Max.Travel	F Mast Height with 2" CAP	
	mm (Inches)	mm Inches
1219 (48")	2032	80
1829 (72")	2642	104

TOP VIEW TYPE-3

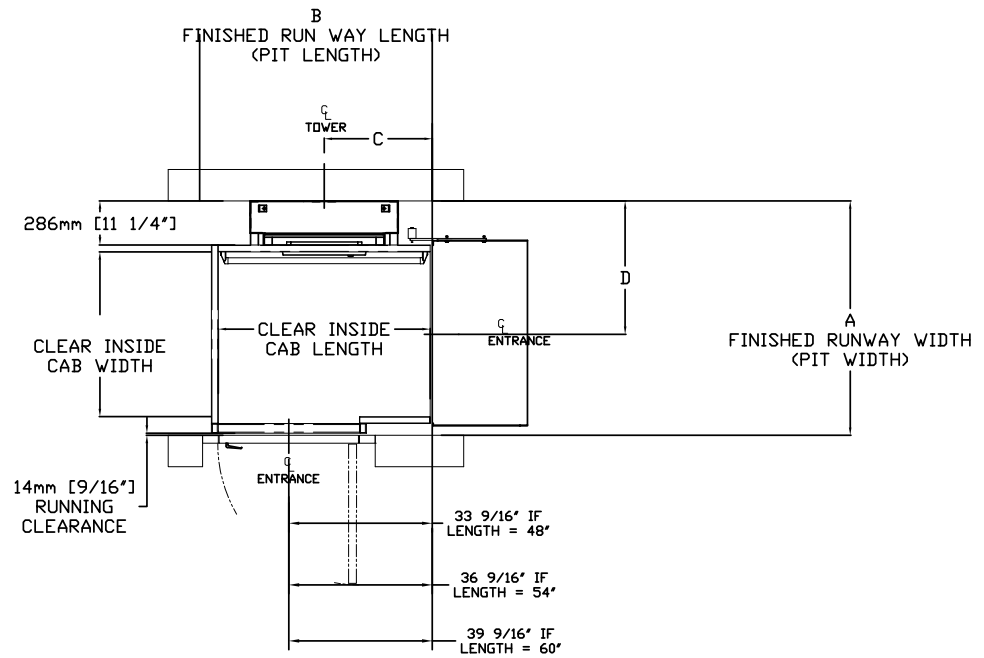

TABLE 2- HOISTWAY DIMENSION

CLEAR INSIDE CAB WIDTH		CLEAR INSIDE CAB LENGTH		A FINISHED RUNWAY WIDTH		B FINISHED RUNWAY LENGTH		C TOWER CENTER LINE		D DOOR CENTER LINE (IN CASE OF 42" DOOR)	
mm	Inches	mm	Inches	mm	Inches	mm	Inches	mm	Inches	mm	Inches
1067	42	1219	48	1518	59 3/4	1354	53 5/16	624	24 9/16	864	34
1067	42	1372	54	1518	59 3/4	1507	59 5/16	700	27 9/16	864	34
1067	42	1524	60	1518	59 3/4	1659	65 5/16	776	30 9/16	864	34

Figure 22: Elevation and plan view – type 4 without platform gate, 42” cab

ELEVATION VIEW TYPE-4

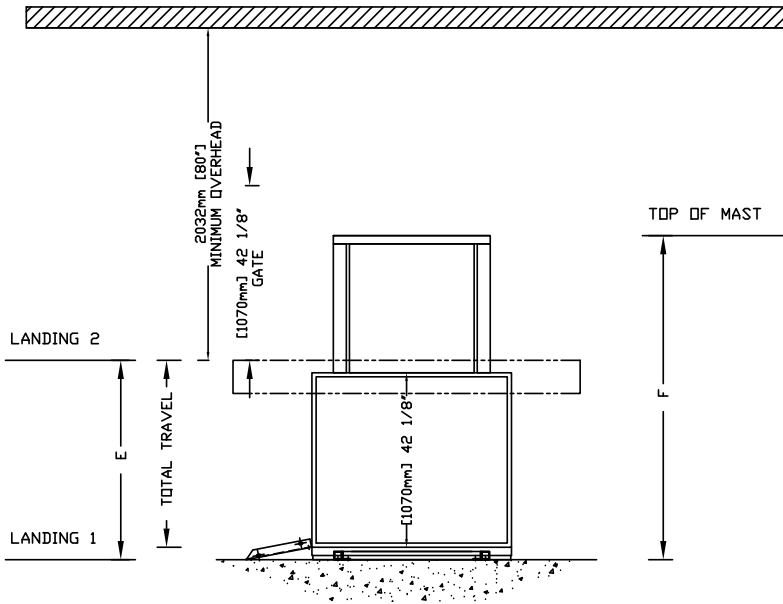
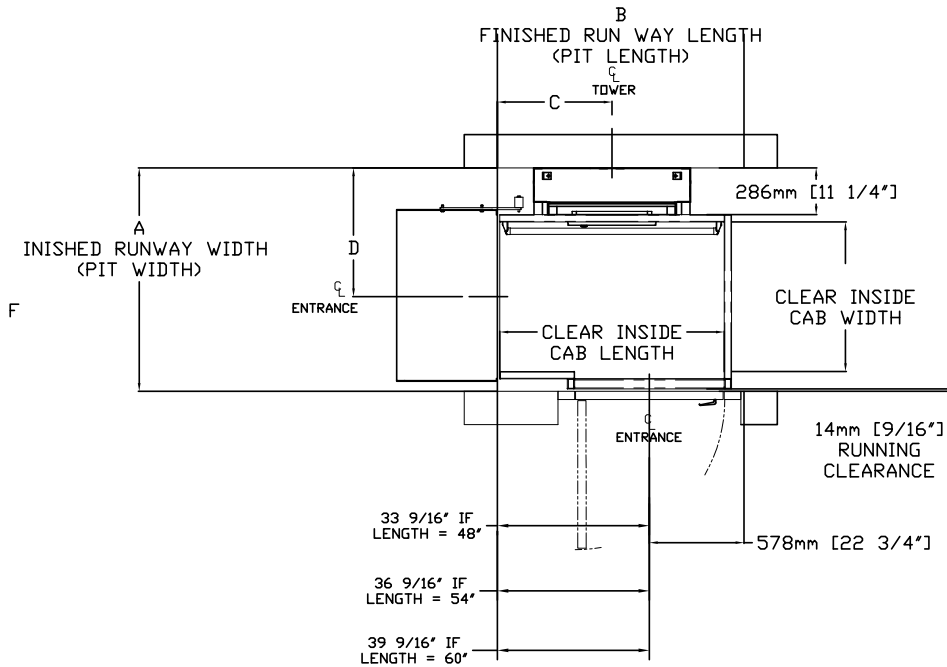

TABLE 1 – MAST HEIGHT

E Max.Travel	F Mast Height with 2" CAP	
	mm (Inches)	mm Inches
1219 (48")	2032	80
1829 (72")	2642	104

TOP VIEW TYPE-4



CLEAR INSIDE CAB WIDTH		CLEAR INSIDE CAB LENGTH		A FINISHED RUNWAY WIDTH		B FINISHED RUNWAY LENGTH		C TOWER CENTER LINE		D DOOR CENTER LINE (IN CASE OF 42" DOOR)	
mm	Inches	mm	Inches	mm	Inches	mm	Inches	mm	Inches	mm	Inches
1067	42	1219	48	1518	59 3/4	1354	53 5/16	624	24 9/16	864	34
1067	42	1372	54	1518	59 3/4	1507	59 5/16	700	27 9/16	864	34
1067	42	1524	60	1518	59 3/4	1659	65 5/16	776	30 9/16	864	34

Figure 23: Elevation and plan view – type 2 with platform gate, 42” cab

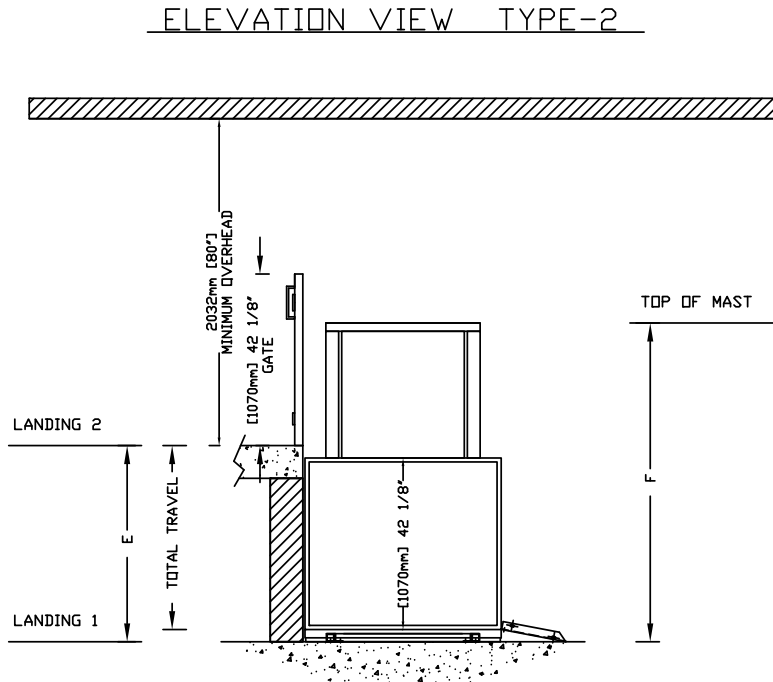

TABLE 1 - MAST HEIGHT

E Max.Travel	F Mast Height with 2" CAP	
	mm (Inches)	mm Inches
1219 (48")	2032	80
1829 (72")	2642	104

TOP VIEW TYPE-2

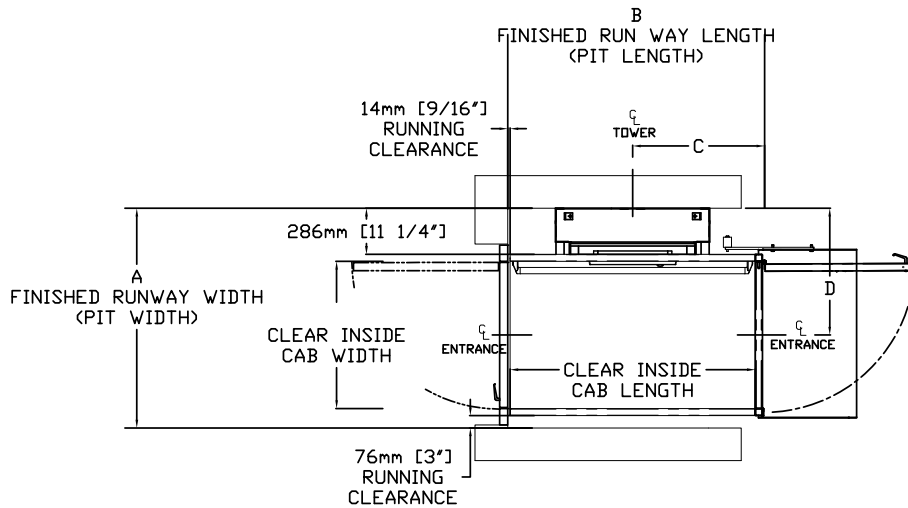

TABLE 2- HOISTWAY DIMENSION

CLEAR INSIDE CAB WIDTH		CLEAR INSIDE CAB LENGTH		A FINISHED RUNWAY WIDTH		B FINISHED RUNWAY LENGTH		C TOWER CENTER LINE		D DOOR CENTER LINE (IN CASE OF 42" DOOR)	
mm	Inches	mm	Inches	mm	Inches	mm	Inches	mm	Inches	mm	Inches
1067	42	1219	48	1518	59 3/4	1292	50 7/8	624	26 5/16	864	34
1067	42	1372	54	1518	59 3/4	1445	56 7/8	700	29 5/16	864	34
1067	42	1524	60	1518	59 3/4	1597	62 7/8	776	32 5/16	864	34

Figure 24: Elevation and plan view – type 3 (42" B side opening) with platform gate, 42" cab

ELEVATION VIEW TYPE-3

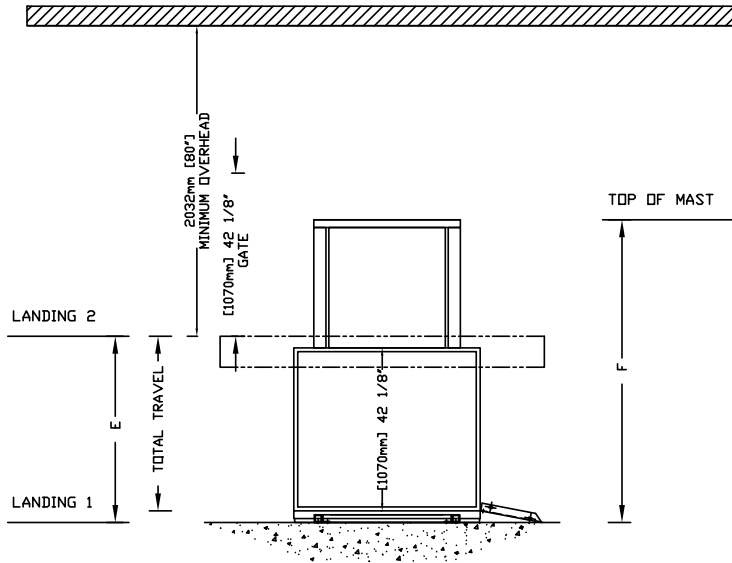

TABLE 1 – MAST HEIGHT

E Max.Travel	F Mast Height with 2" CAP	
	mm (Inches)	mm Inches
1219 (48")	2032	80
1829 (72")	2642	104

TOP VIEW TYPE-3

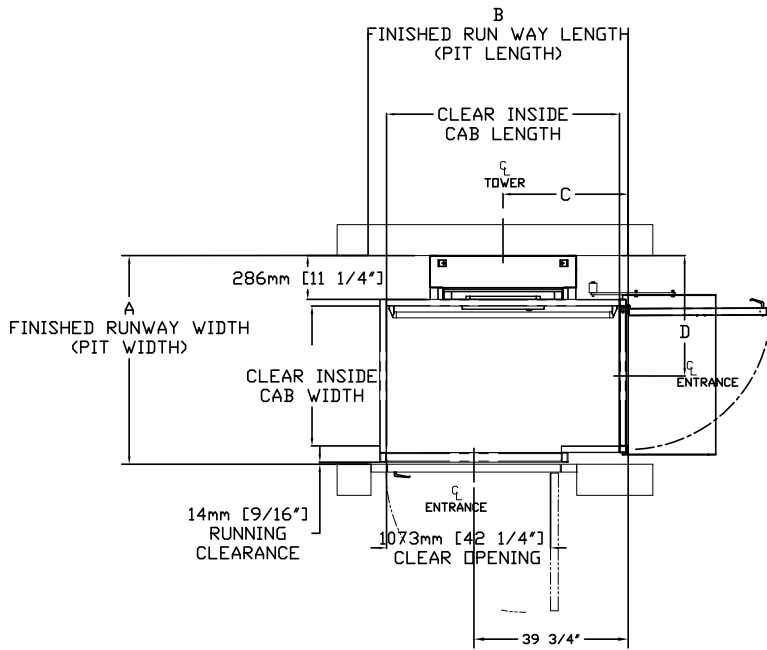

TABLE 2- HOISTWAY DIMENSION

CLEAR INSIDE CAB WIDTH		CLEAR INSIDE CAB LENGTH		A FINISHED RUNWAY WIDTH		B FINISHED RUNWAY LENGTH		C TOWER CENTER LINE		D DOOR CENTER LINE (IN CASE OF 42" DOOR)	
mm	Inches	mm	Inches	mm	Inches	mm	Inches	mm	Inches	mm	Inches
1067	42	1219	48	1518	59 3/4	1397	55	624	26 1/4	864	34
1067	42	1372	54	1518	59 3/4	1549	61	700	29 1/4	864	34
1067	42	1524	60	1518	59 3/4	1702	67	776	32 1/4	864	34

Figure 25: Elevation and plan view – type 4 with platform gate, 42” cab

ELEVATION VIEW TYPE-4

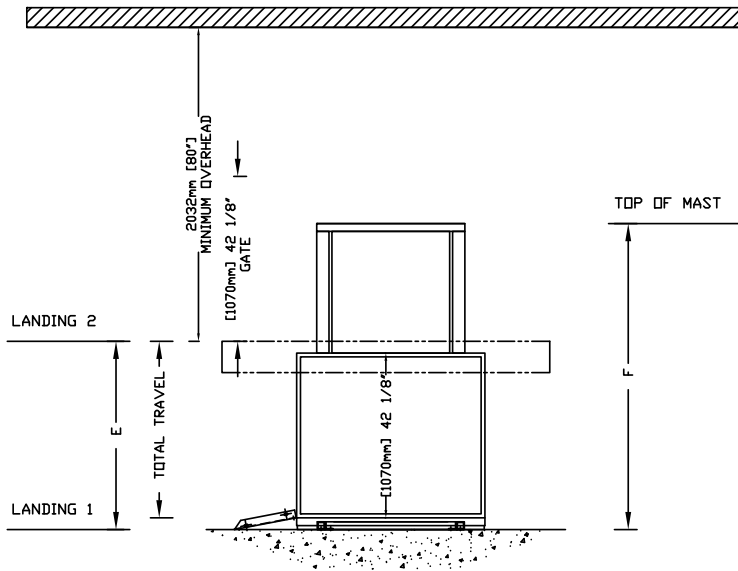

TABLE 1 – MAST HEIGHT

E Max.Travel	F Mast Height with 2" CAP	
	mm (Inches)	mm Inches
1219 (48")	2032	80
1829 (72")	2642	104

TOP VIEW TYPE-4

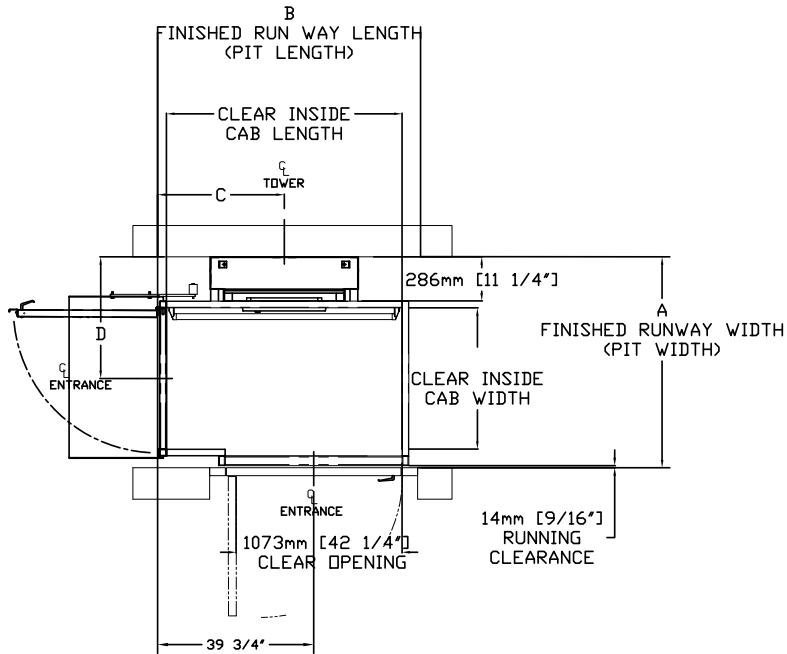

TABLE 2- HOISTWAY DIMENSION

CLEAR INSIDE CAB WIDTH		CLEAR INSIDE CAB LENGTH		A FINISHED RUNWAY WIDTH		B FINISHED RUNWAY LENGTH		C TOWER CENTER LINE		D DOOR CENTER LINE (IN CASE OF 42" DOOR)	
mm	Inches	mm	Inches	mm	Inches	mm	Inches	mm	Inches	mm	Inches
1067	42	1219	48	1518	59 3/4	1397	55	624	26 1/4	864	34
1067	42	1372	54	1518	59 3/4	1549	61	700	29 1/4	864	34
1067	42	1524	60	1518	59 3/4	1702	67	776	32 1/4	864	34

Figure 26: Elevation and plan view - type 2, enclosure, 36" cab

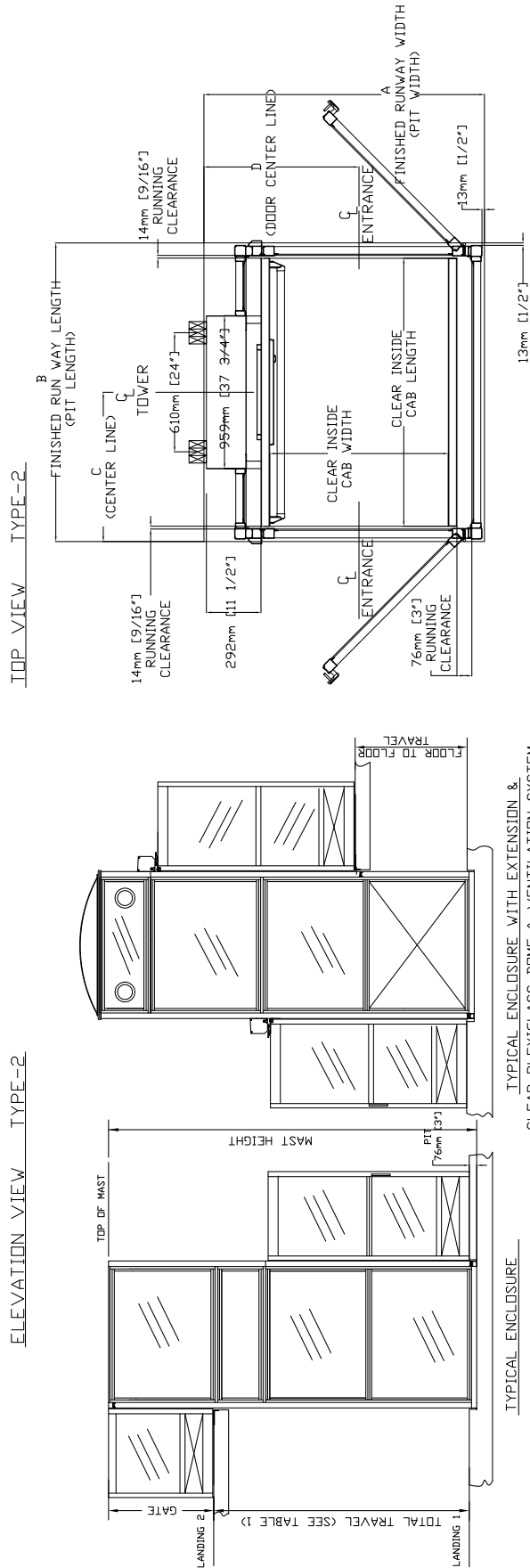

TABLE 1 - MAST HEIGHT

TRAVEL	TOWER HEIGHT	MIN ENCLOSURE HEIGHT
mm (inches)	mm (inches)	mm (inches)
1219 (48")	2032 (80)	2286 (90)
1829 (72")	2642 (104)	2896 (114)

TABLE 2 - ENCLOSURE DIMENSION

CLEAR INSIDE CAB WIDTH		CLEAR INSIDE CAB LENGTH		A FINISHED RUNWAY WIDTH		B FINISHED RUNWAY LENGTH		C TOWER CENTER LINE		D DOOR CENTER LINE (IN CASE OF 36" DOOR)	
mm	Inches	mm	Inches	mm	Inches	mm	Inches	mm	Inches	mm	Inches
914	36	1219	48	57 7/16	54 3/16	687	27 1/16	27 1/16	808	31 3/4	31 3/4
914	36	1372	54	449	57 7/16	1529	60 3/16	784	30 7/16	808	31 3/4
914	36	1524	60	449	57 7/16	1681	66 3/16	840	33 1/16	808	31 3/4

Figure 27: Elevation and plan view - type 3, enclosure, 36" cab

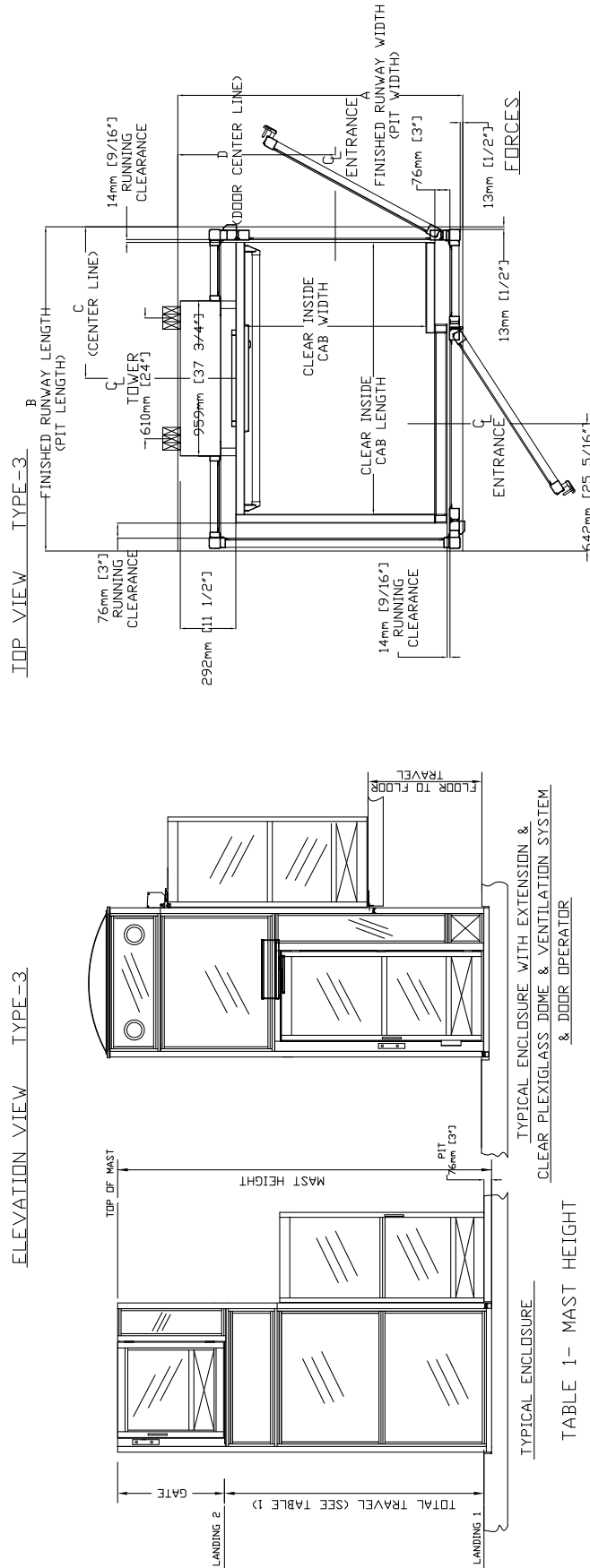

TABLE 2 - ENCLOSURE DIMENSION

CLEAR INSIDE CAB WIDTH	CLEAR INSIDE CAB LENGTH		A FINISHED RUNWAY WIDTH		B FINISHED RUNWAY LENGTH		C TOWER CENTER LINE		D DOOR CENTER LINE (IN CASE OF 36" DOOR)	
	mm	Inches	mm	Inches	mm	Inches	mm	Inches	mm	Inches
914	36	1219	1449	57 1/16	1483	58 3/8	687	27 1/16	806	31 3/4
914	36	1372	1449	57 1/16	1635	64 3/8	764	30 1/16	806	31 3/4
914	36	1524	1449	57 1/16	1788	70 3/8	840	33 1/16	806	31 3/4

TABLE 1- MAST HEIGHT

TRAVEL	TOWER HEIGHT	MIN ENCLOSURE HEIGHT
mm (Inches)	mm	Inches
1219 (48")	2032	80
1829 (72")	2642	104
		2896
		114

Figure 28: Elevation and plan view - type 3 (45" opening), enclosure, 36" cab

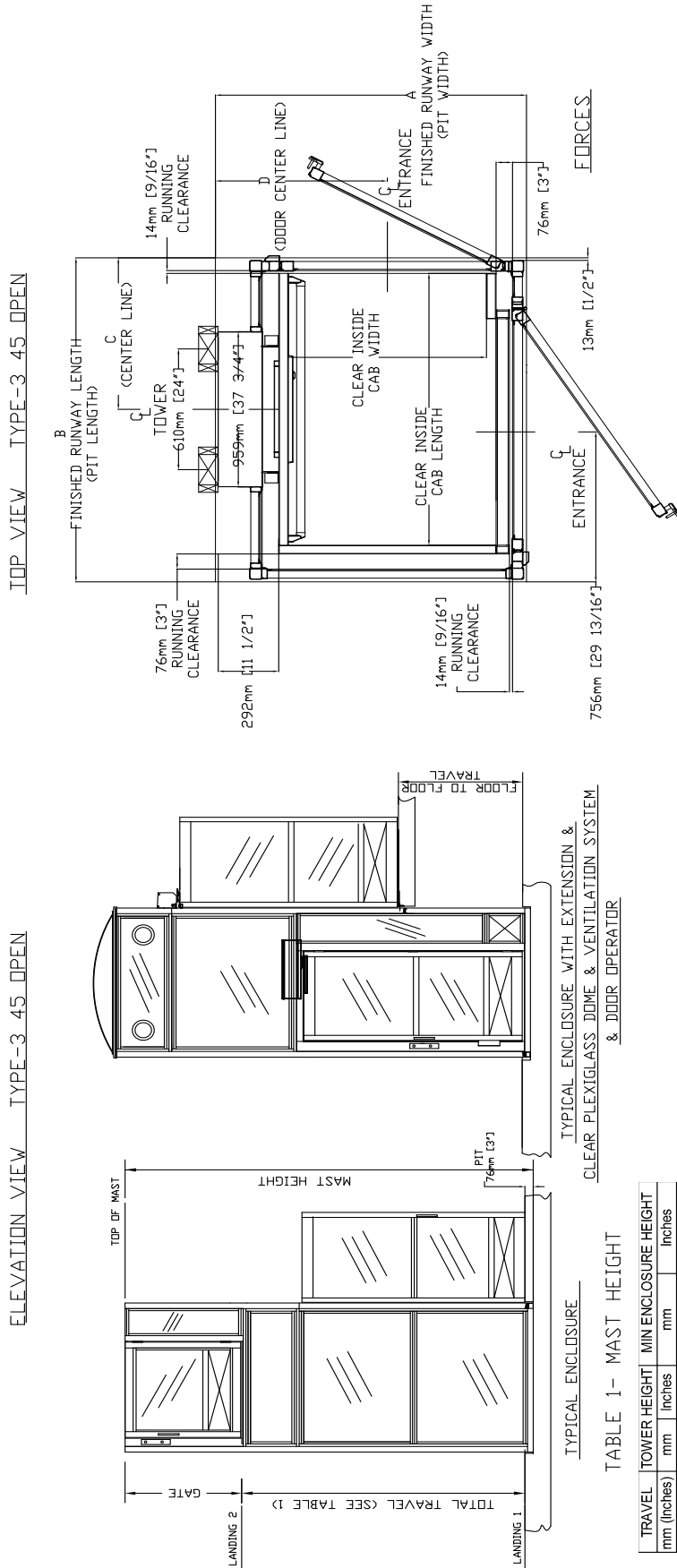

TABLE 1 - MAST HEIGHT

TRAVEL	TOWER HEIGHT	MIN ENCLOSURE HEIGHT
mm (inches)	mm (inches)	mm (inches)
1219 (48")	80	2286 90
1829 (72")	104	2896 114

TABLE 2 - ENCLOSURE DIMENSION

CLEAR INSIDE CAB WIDTH	A		B		C		D	
	FINISHED RUNWAY WIDTH	FINISHED RUNWAY LENGTH	FINISHED RUNWAY LENGTH	TOWER CENTER LINE	TOWER CENTER LINE	DOOR CENTER LINE	DOOR CENTER LINE	
mm	mm	mm	mm	mm	mm	mm	mm	
914	1449	1483	59 3/8	607	27 1/16	806	31 3/4	
914	1449	1635	64 3/8	764	30 1/16	806	31 3/4	
914	1449	1788	70 3/8	840	33 1/16	806	31 3/4	

Figure 29: Elevation and plan view - type 4, enclosure, 36" cab

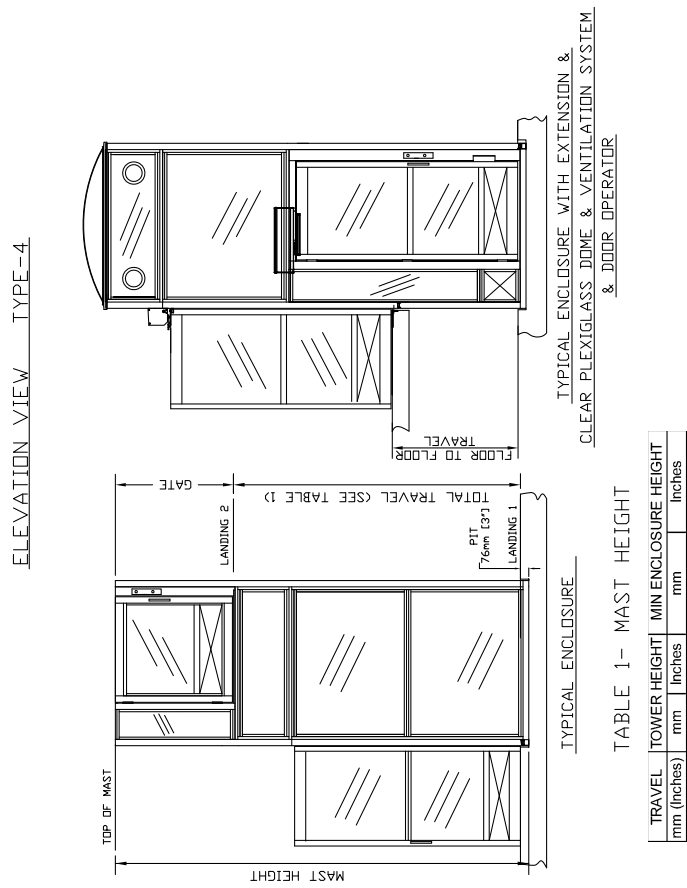
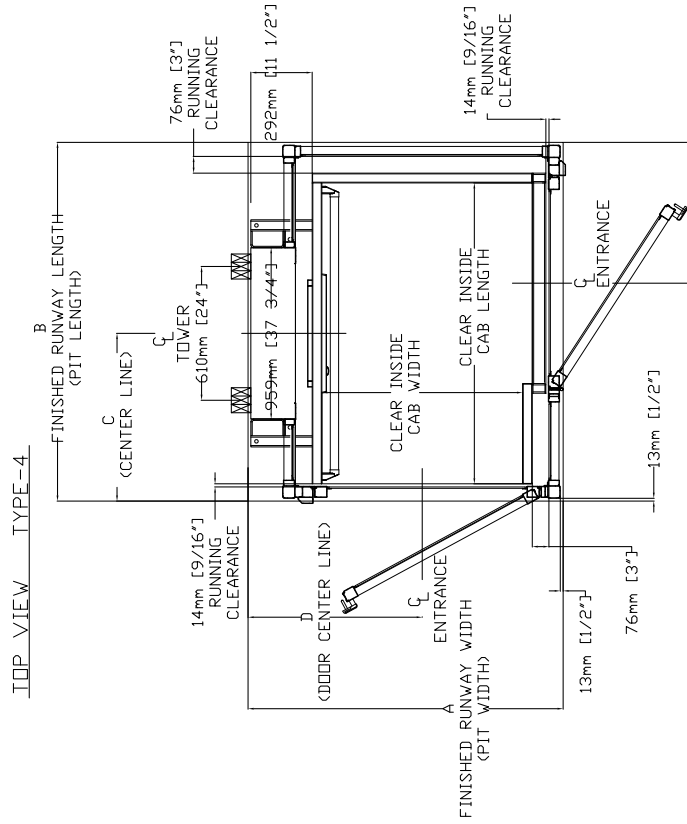

TABLE 2 - ENCLOSURE DIMENSION

CLEAR INSIDE CAB WIDTH	A		B		C		D	
	CLEAR INSIDE CAB LENGTH	FINISHED RUNWAY WIDTH	FINISHED RUNWAY LENGTH	TOWER CENTER LINE	DOOR CENTER LINE (IN CASE OF 36" DOOR)			
Inches	Inches	Inches	Inches	Inches	Inches			
mm	mm	mm	mm	mm	mm			
914	1219	1449	1483	667	806			
36	48	57	58	27	31.3/4			
914	1372	1449	1635	667	806			
36	54	57	64	30	31.3/4			
914	1524	1449	1788	840	806			
36	60	57	70	33	31.3/4			

TABLE 1 - MAST HEIGHT

TRAVEL	TOWER HEIGHT	MIN ENCLOSURE HEIGHT
mm (Inches)	mm (Inches)	mm (Inches)
1219 (48")	2032	80
1829 (72")	2642	104
		2886
		114

Figure 30: Elevation and plan view - type 4 (45" opening), enclosure, 36" cab

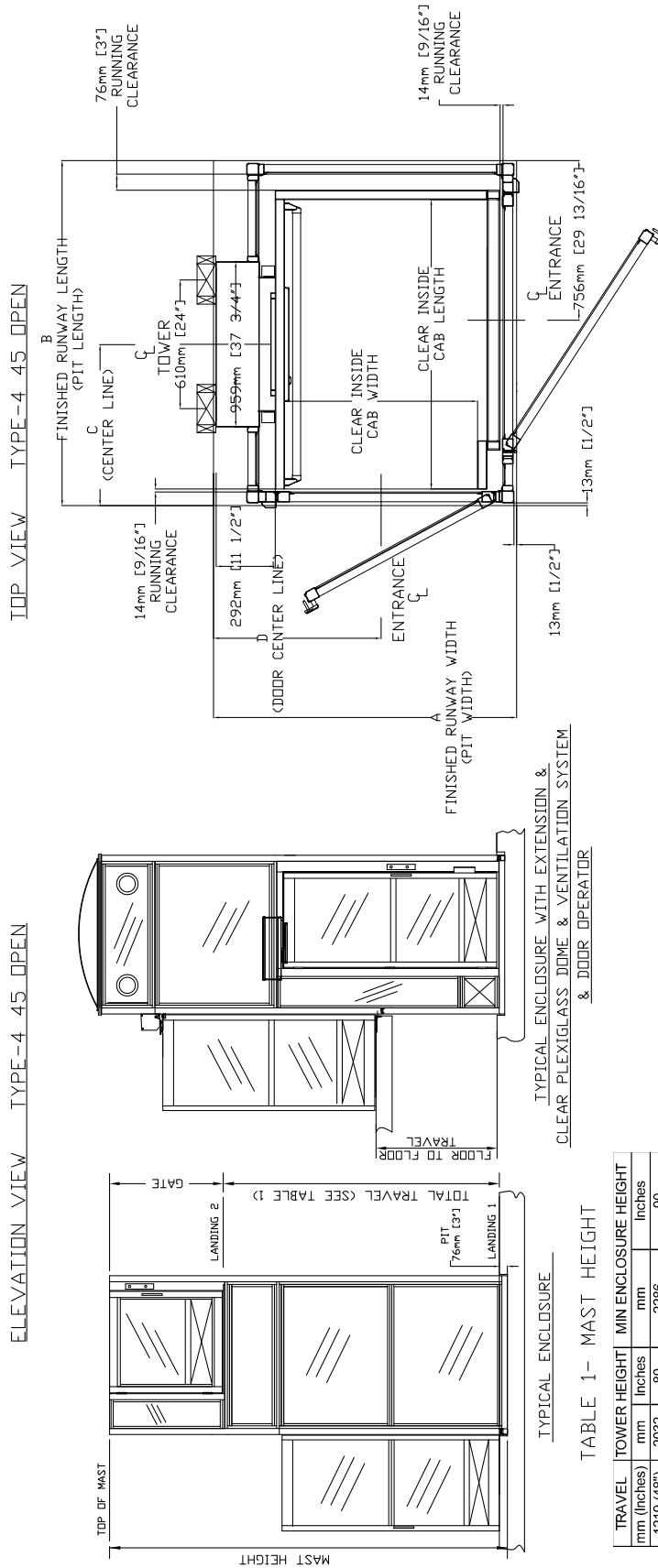

TABLE 1- MAST HEIGHT

TRAVEL (Inches)	TOWER HEIGHT (mm)	TOWER HEIGHT (Inches)	MIN ENCLOSURE HEIGHT (mm)	MIN ENCLOSURE HEIGHT (Inches)
1219 (48")	2032	80	2286	90
1829 (72")	2642	104	2896	114

TABLE 2 - ENCLOSURE DIMENSION

CLEAR INSIDE CAB WIDTH	CLEAR INSIDE CAB LENGTH		FINISHED RUNWAY WIDTH		FINISHED RUNWAY LENGTH		TOWER CENTER LINE		DOOR CENTER LINE (IN CASE OF 36" DOOR)	
	mm	Inches	mm	Inches	mm	Inches	mm	Inches	mm	Inches
974	36	1219	46	57-1/16	1483	58-3/8	587	23-1/8	605	23-3/4
974	36	1372	54	57-1/16	1635	64-3/8	784	30-1/8	805	31-3/4
974	36	1524	60	57-1/16	1788	70-3/8	840	33-1/8	865	33-3/4

Figure 31: Elevation and plan view – type 2 enclosure, 42” cab

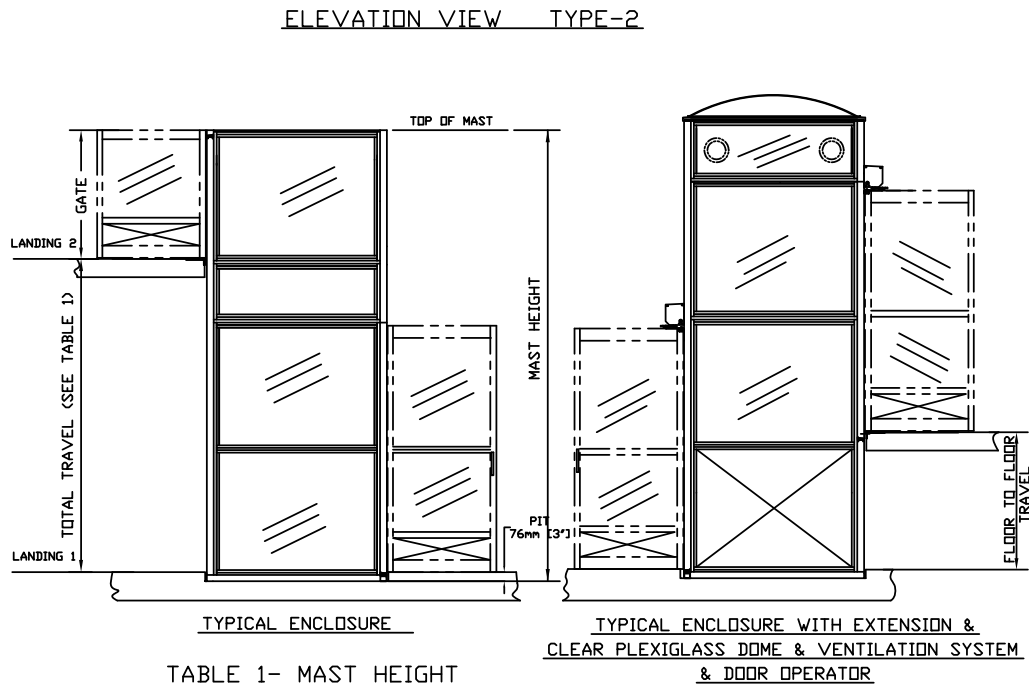

TABLE 1- MAST HEIGHT

TRAVEL	TOWER HEIGHT		MIN ENCLOSURE HEIGHT	
mm (Inches)	mm	Inches	mm	Inches
1219 (48")	2032	80	2286	90
1829 (72")	2642	104	2896	114

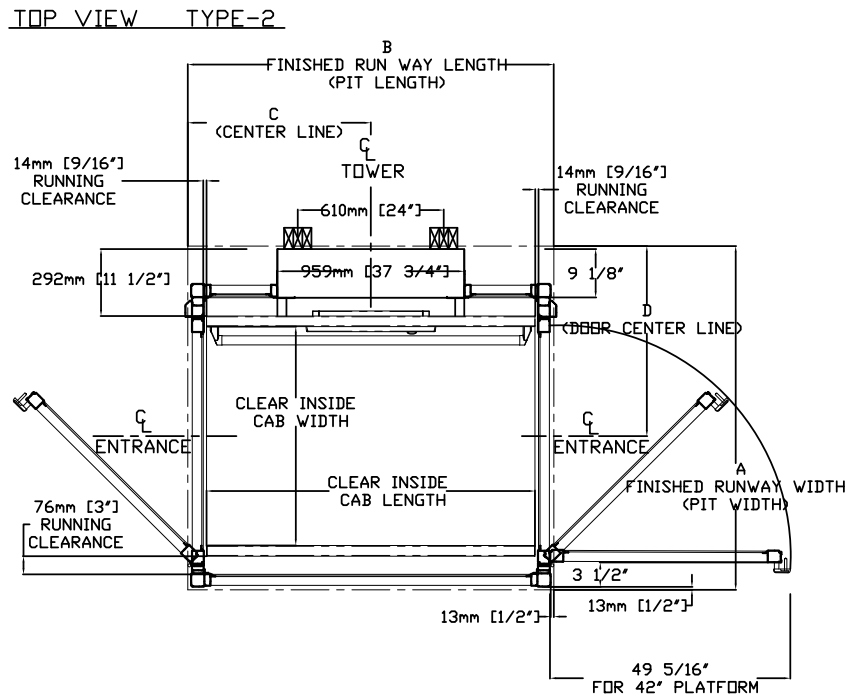

TABLE 2 - ENCLOSURE DIMENSION

CLEAR INSIDE CAB WIDTH		CLEAR INSIDE CAB LENGTH		A FINISHED RUNWAY WIDTH		B FINISHED RUNWAY LENGTH		C TOWER CENTER LINE		D DOOR CENTER LINE (IN CASE OF 36" DOOR)	
mm	Inches	mm	Inches	mm	Inches	mm	Inches	mm	Inches	mm	Inches
1067	42	1219	48	1589	62 9/16	1376	54 3/16	687	27 1/16	883	34 3/4
1067	42	1372	54	1589	62 9/16	1529	60 3/16	764	30 1/16	883	34 3/4
1067	42	1524	60	1589	62 9/16	1681	66 3/16	840	33 1/16	883	34 3/4

Figure 32: Elevation and plan view – type 3 enclosure, 42” cab

ELEVATION VIEW TYPE-3

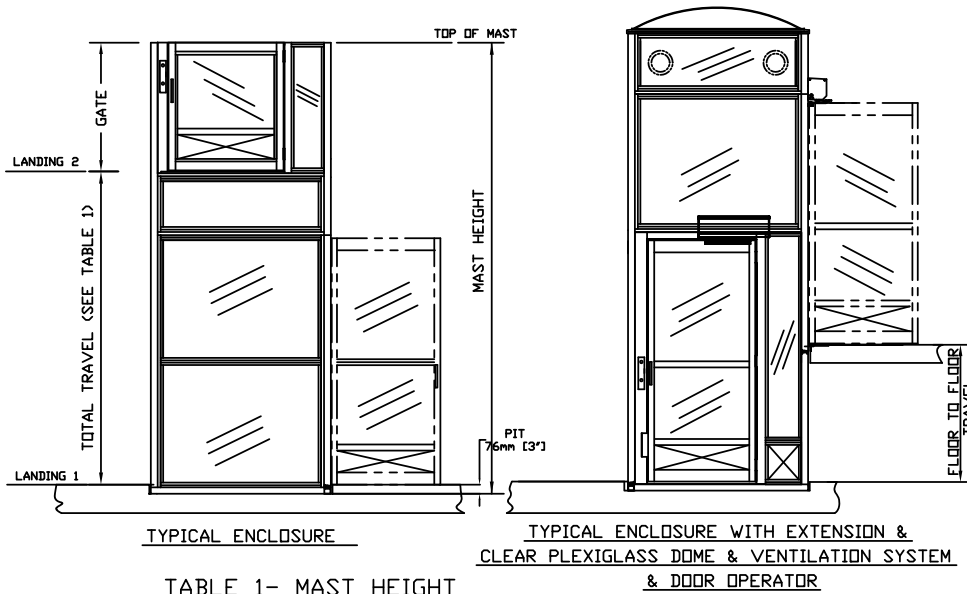

TABLE 1- MAST HEIGHT

TRAVEL mm (Inches)	TOWER HEIGHT		MIN ENCLOSURE HEIGHT	
	mm	Inches	mm	Inches
1219 (48")	2032	80	2286	90
1829 (72")	2642	104	2896	114

TOP VIEW TYPE-3

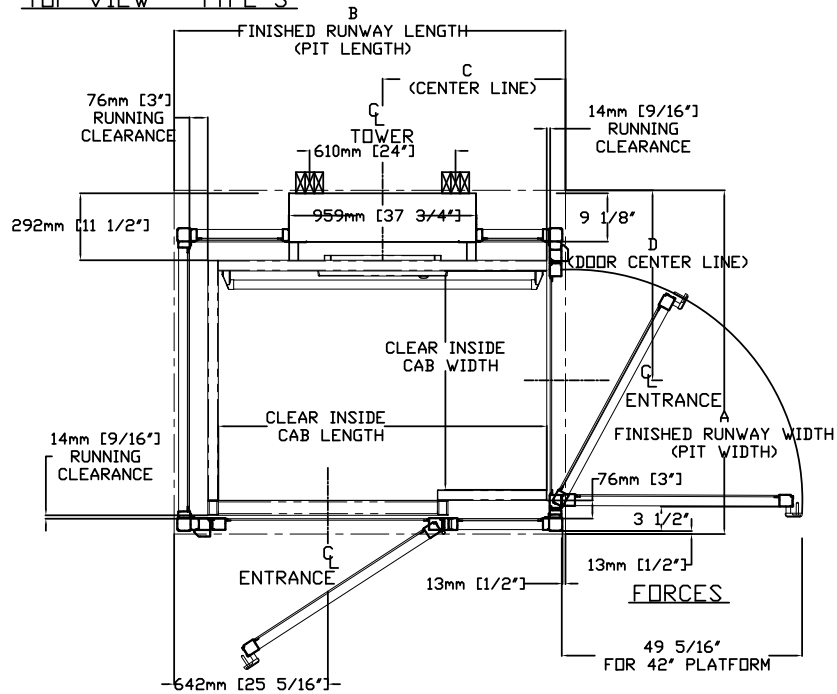

TABLE 2 - ENCLOSURE DIMENSION

CLEAR INSIDE CAB WIDTH		CLEAR INSIDE CAB LENGTH		A FINISHED RUNWAY WIDTH		B FINISHED RUNWAY LENGTH		C TOWER CENTER LINE		D DOOR CENTER LINE (IN CASE OF 36" DOOR)	
mm	Inches	mm	Inches	mm	Inches	mm	Inches	mm	Inches	mm	Inches
1067	42	1219	48	1602	63 1/16	1483	58 3/8	687	27 1/16	883	34 3/4
1067	42	1372	54	1602	63 1/16	1635	64 3/8	764	30 1/16	883	34 3/4
1067	42	1524	60	1602	63 1/16	1788	70 3/8	840	33 1/16	883	34 3/4

Figure 33: Elevation and plan view – type 4 enclosure, 42” cab

ELEVATION VIEW TYPE-4

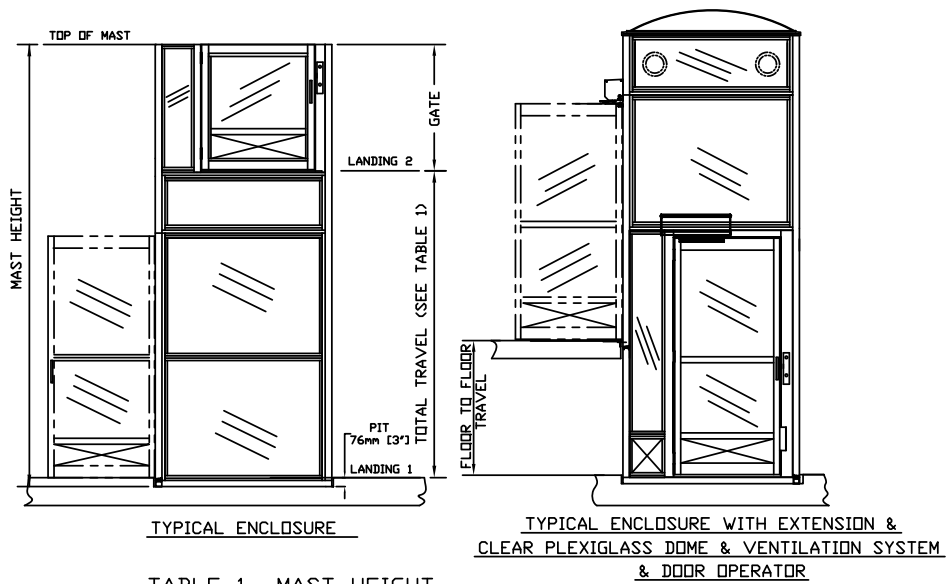

TABLE 1- MAST HEIGHT

TRAVEL	TOWER HEIGHT		MIN ENCLOSURE HEIGHT	
	mm	Inches	mm	Inches
1219 (48")	2032	80	2286	90
1829 (72")	2642	104	2896	114

TOP VIEW TYPE-4

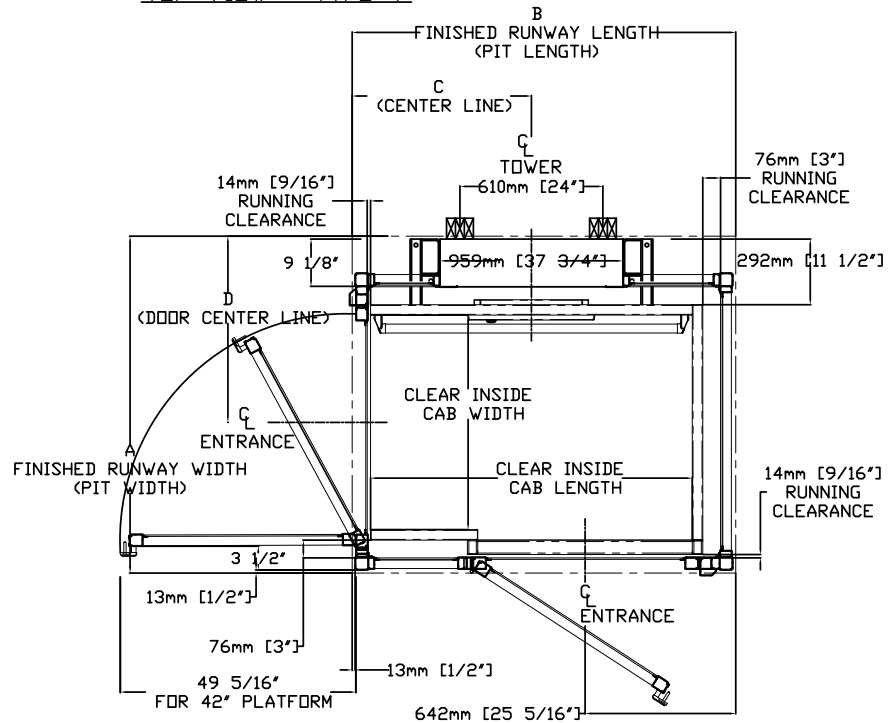

TABLE 2 - ENCLOSURE DIMENSION

CLEAR INSIDE CAB WIDTH		CLEAR INSIDE CAB LENGTH		A FINISHED RUNWAY WIDTH		B FINISHED RUNWAY LENGTH		C TOWER CENTER LINE		D DOOR CENTER LINE (IN CASE OF 36" DOOR)	
mm	Inches	mm	Inches	mm	Inches	mm	Inches	mm	Inches	mm	Inches
1067	42	1219	48	1602	63 1/16	1483	58 3/8	687	27 1/16	883	34 3/4
1067	42	1372	54	1602	63 1/16	1635	64 3/8	784	30 1/16	883	34 3/4
1067	42	1524	60	1602	63 1/16	1788	70 3/8	840	33 1/16	883	34 3/4

Figure 34: Elevation and plan view - type 2, three gates

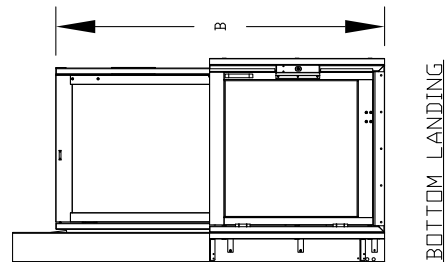
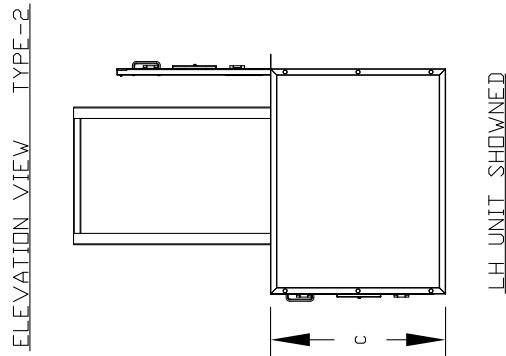
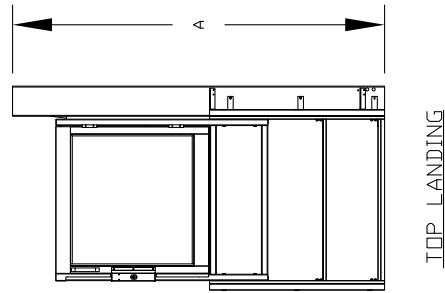
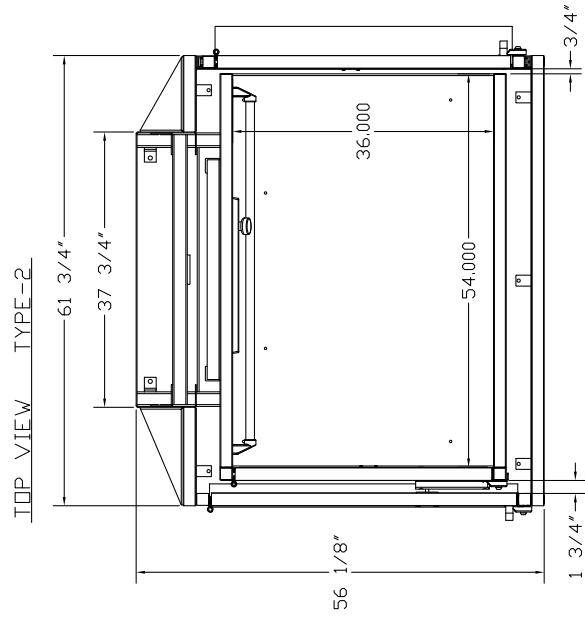

TABLE 1- MAST HEIGHT

TRAVEL	TOWER HEIGHT			GATE HEIGHT			WALL HEIGHT			
	A	B	C	A	B	C	A	B	C	
mm (inches)	mm	inches	mm	mm	inches	mm	mm	inches	mm	inches
1219 (48")	1981	76	2289	90 1/8	1219	48				

Figure 35: 42" x 36" Auto left-hand gate

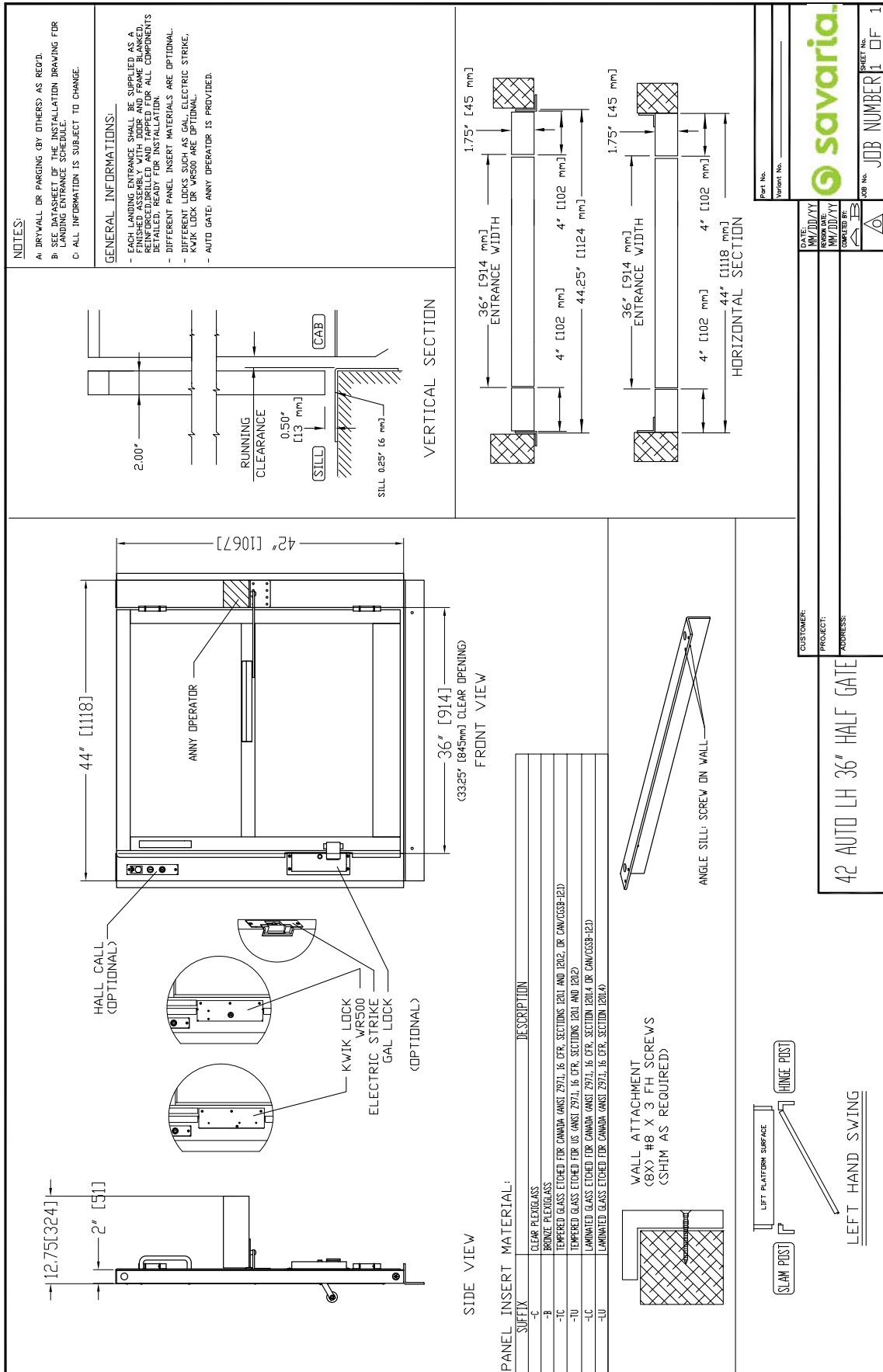
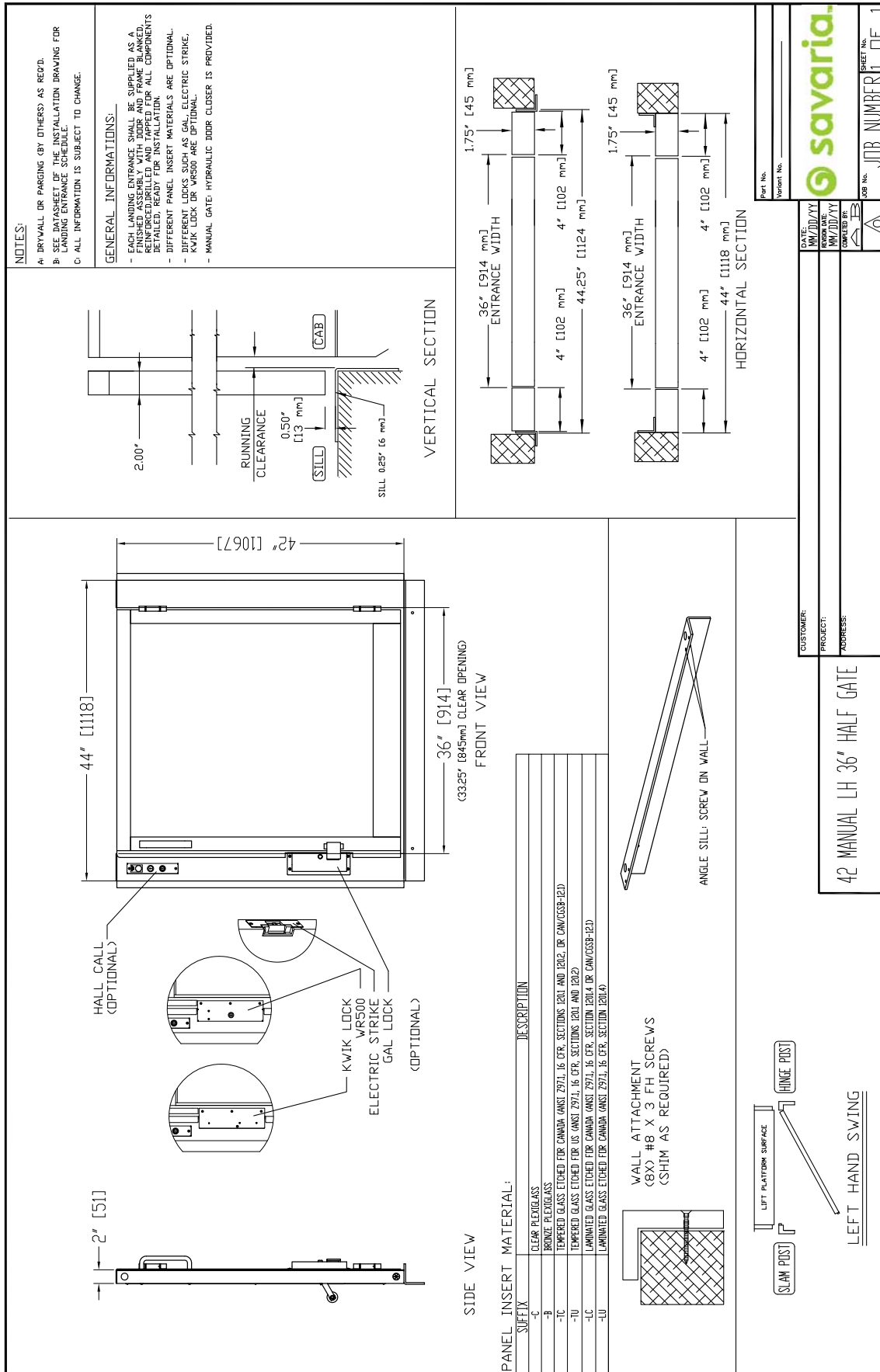

Figure 36: 42" x 36" Manual left-hand gate



CUSTOMER: _____

PROJECT: _____

ADDRESS: _____

42 MANUAL LH 36" HALF GATE

Part No. _____

Version No. _____

JOB No. _____

SHEET No. **1** OF **1**

Provisions by others

PROVISIONS BY OTHERS

GENERAL

HOISTWAY - THE HOISTWAY MUST BE DESIGNED AND BUILT IN ACCORDANCE WITH 'SAFETY STANDARD FOR PLATFORM LIFTS AND STAIRWAY CHAIRLIFTS' OR 'SAFETY CODE FOR ELEVATORS AND ESCALATORS' AND ALL STATE/PROVINCIALS AND LOCAL CODES.

PLUMB RUNWAY- DUE TO CLOSE RUNNING CLEARANCES OWNER/AGENT MUST ENSURE THAT HOISTWAY AND PIT (WHERE PROVIDED) ARE LEVEL, PLUMB ($\pm 1/8''$ (3 mm)) AND SQUARE AND ARE IN ACCORDANCE WITH THE DIMENSIONS ON THESE DRAWINGS.

MINIMUM OVERHEAD CLEARANCE- OWNER/AGENT MUST ENSURE MINIMUM OVERHEAD CLEARANCE IS IN COMPLIANCE WITH CODES.

CONSTRUCTION SITE- OWNER/AGENT TO PROVIDE ALL MASONRY, CARPENTRY AND DRYWALL WORK AS REQUIRED AND SHALL PATCH AND MAKE GOOD (INCLUDING FINISH PAINTING) ALL AREAS WHERE WALLS/FLOORS MAY REQUIRE TO BE CUT, DRILLED OR ALTERED IN ANY WAY TO PERMIT THE PROPER INSTALLATION OF THE LIFT.

DIMENSIONS- CONTRACTOR/CUSTOMER TO VERIFY ALL DIMENSIONS AND REPORT ANY DISCREPANCIES TO OUR OFFICE IMMEDIATELY.

STRUCTURAL

FLOOR/SUPPORT WALL LOADS-STRUCTURAL ENGINEER TO ASSURE THAT BUILDING AND SHAFT WILL SAFELY SUPPORT ALL LOADS IMPOSED BY THE LIFT EQUIPMENT. REFER TO THE LOAD DIAGRAM ON THIS DRAWING.

MAST TO BE SECURELY FASTENED- WHERE REQUIRED THE MAST MUST BE SECURELY FASTENED TO THE STRUCTURAL SUPPORT WALL. REFER TO WALL / FLOOR SUPPORT LOAD DIAGRAM AND WALL LAG DIMENSIONS ON THIS DRAWING.

WHERE DOORS ARE REQUIRED- SUITABLE LINTELS MUST BE PROVIDED BY OWNER/AGENT. DOOR FRAMES ARE NOT DESIGNED TO SUPPORT OVERHEAD WALL LOADS.

ELECTRICAL

GENERAL- ELECTRICAL EQUIPMENT AND WIRING TO COMPLY WITH SECTION 38 OF CSA C22.1 (CANADA) OR SECTION 620 OF NEC ANSI/NFPA 70 (USA).

POWER SUPPLY- 120VAC, 20A, 60HZ, 1PH CIRCUIT THROUGH A FUSE DISCONNECT WITH AUXILIARY CONTACT ON MAIN POWER SUPPLY. PROVIDE TWO 18 AWG CONDUCTORS BETWEEN CONTACT AND CONTROLLER.

LIGHTING- LIGHTING OF 100 LX MIN. AT PLATFORM AND LANDINGS. LIGHTING WITH SWITCH AND ELECTRICAL GFCI OUTLET IN HOISTWAY PIT.

ADDITIONAL BRANCH CIRCUIT- BRANCH CIRCUIT WITH DISCONNECT FOR DOOR OPERATORS (IF EQUIPPED) (120VAC, 15A, 60HZ, 1PH) BRANCH CIRCUIT WITH DISCONNECT FOR VENTILATION SYSTEM (IF EQUIPPED) (120VAC, 15A, 60HZ, 1PH)

ENTRANCES

UPPER LANDING GATES- WHERE REQUIRED, SMOOTH SOLID BARRIERS ARE TO BE SUPPLIED AND INSTALLED ON BOTH SIDES OF ENTRANCE AT UPPER LEVEL AND MUST BE A MINIMUM OF 42" (1067 mm) HIGH. ENTRANCE ASSEMBLY MUST BE IN PLACE PRIOR TO THIS PROVISION.

FASCIA PANEL BELOW UPPER LEVEL ENTRANCE- WHERE REQUIRED, FASCIA PANEL MUST BE FASTENED TO A SOLID WALL AND BE PERPENDICULAR TO THE FLOOR AND WALLS. HOISTWAY FASCIA IS NOT SELF-SUPPORTING FOR LONG, CONTINUOUS RUNS VOID OF ENTRANCES. ADEQUATE SUPPORT FOR THE FASCIA MUST BE PROVIDED.

ENTRANCE ASSEMBLIES- ENTRANCE ASSEMBLIES MUST BE ADJUSTED TO ALIGN WITH PLATFORM AND INTERLOCK EQUIPMENT. OTHERS TO ALLOW AN ADEQUATE ROUGH OPENING.

RETURN WALLS- RETURN WALLS AT ENTRANCES MUST BE BUILT-IN BY OTHERS AFTER ENTRANCE ASSEMBLIES ARE IN PLACE. ENTRANCE ASSEMBLY MUST BE SECURELY FASTENED TO WALLS.

ALL INFORMATION IS SUBJECT TO CHANGE.
PLEASE REFERENCE OUR ON-LINE DRAWINGS AT
www.savaria.com FOR THE MOST RECENT UPDATES

MULTILIFT
VERTICAL
PLATFORM LIFTS

THE INFORMATION DISCLOSED HEREIN IS THE EXCLUSIVE PROPERTY OF
 savaria
SHEET 1/1
AND MAY NOT BE USED BY OTHERS WITHOUT PRIOR WRITTEN CONSENT

Multilift RESIDENTIAL Vertical Platform Lift PLANNING GUIDE

Part No. 000736
Copyright © 2019

Savaria Concord Lifts, Inc.
www.savaria.com

Sales
2 Walker Drive
Brampton, Ontario L6T 5E1
Canada
Tel: (905) 791-5555
Fax: (905) 791-2222
Toll Free: 1-800-661-5112

